

SECTION **RF**
ROOF

A
B
C

CONTENTS

PRECAUTION	3	ECU DIAGNOSIS INFORMATION	17	F
PRECAUTIONS	3	BCM (BODY CONTROL MODULE)	17	G
Precaution for Supplemental Restraint System (SRS) "AIR BAG" and "SEAT BELT PRE-TENSIONER"	3	List of ECU Reference	17	
Procedure without Cowl Top Cover	3	MOONROOF MOTOR ASSEMBLY	18	H
Precaution for Work	3	Reference Value	18	
PREPARATION	5	SUNSHADE MOTOR ASSEMBLY	19	I
PREPARATION	5	Reference Value	19	
Special Service Tool	5	WIRING DIAGRAM	20	J
Commercial Service Tools	5	MOONROOF SYSTEM	20	
CLIP LIST	6	Wiring Diagram	20	
Descriptions for Clips	6	BASIC INSPECTION	25	
SYSTEM DESCRIPTION	10	DIAGNOSIS AND REPAIR WORKFLOW	25	RF
COMPONENT PARTS	10	Work Flow	25	
Component Parts Location	10	INSPECTION AND ADJUSTMENT	27	L
Component Description	10	ADDITIONAL SERVICE WHEN REPLACING CONTROL UNIT	27	M
Moonroof Switch	11	ADDITIONAL SERVICE WHEN REPLACING CONTROL UNIT : Special Repair Requirement	27	
Moonroof Motor Assembly	11	DTC/CIRCUIT DIAGNOSIS	28	N
Sunshade Motor Assembly	11	POWER SUPPLY AND GROUND CIRCUIT	28	
SYSTEM	12	BODY CONTROL SYSTEM	28	O
MOONROOF	12	BODY CONTROL SYSTEM : Diagnosis Procedure	28	
MOONROOF : System Diagram	12	MOONROOF MOTOR ASSEMBLY	28	P
MOONROOF : System Description	12	MOONROOF MOTOR ASSEMBLY : Description.....	28	
DIAGNOSIS SYSTEM (BCM)	14	MOONROOF MOTOR ASSEMBLY :		
COMMON ITEM	14	Component Function Check	29	
COMMON ITEM : CONSULT Function (BCM - COMMON ITEM)	14	MOONROOF MOTOR ASSEMBLY :		
RETAINED PWR	15	Diagnosis Procedure	29	
RETAINED PWR : CONSULT Function (BCM - RETAINED PWR)	15			

MOONROOF MOTOR ASSEMBLY : Special Repair Requirement	31	SQUEAK AND RATTLE TROUBLE DIAG-NOSES	43
SUNSHADE MOTOR ASSEMBLY	31	Work Flow	43
SUNSHADE MOTOR ASSEMBLY : Description ...	31	Generic Squeak and Rattle Troubleshooting	44
SUNSHADE MOTOR ASSEMBLY :		Diagnostic Worksheet	47
Component Function Check	31	REMOVAL AND INSTALLATION	49
SUNSHADE MOTOR ASSEMBLY :		GLASS LID	49
Diagnosis Procedure	31	Exploded View	49
MOONROOF SWITCH	33	Removal and Installation	50
Description	33	MOONROOF MOTOR ASSEMBLY	52
Diagnosis Procedure	33	Exploded View	52
Component Inspection	34	Removal and Installation	52
DOOR SWITCH	36	SUNSHADE MOTOR ASSEMBLY	54
Component Function Check	36	Exploded View	54
Diagnosis Procedure	36	Removal and Installation	54
Component Inspection	37	ROOF LINK ASSEMBLY	56
SYMPTOM DIAGNOSIS	38	Exploded View	56
MOONROOF DOES NOT OPERATE PROPERLY	38	Removal and Installation	56
Diagnosis Procedure	38	MOONROOF UNIT ASSEMBLY	57
SUNSHADE SYSTEM DOES NOT OPERATE PROPERLY	39	Inspection and Adjustment	57
Diagnosis Procedure	39	Exploded View	59
AUTO OPERATION DOES NOT OPERATE	40	Removal and Installation	59
MOONROOF	40	ROOF FINISHER	63
MOONROOF : Diagnosis Procedure	40	Removal and Installation	63
SUNSHADE	40	FRONT SUNROOF GLASS	64
SUNSHADE : Diagnosis Procedure	40	Exploded View	64
ANTI-PINCH FUNCTION DOES NOT OPERATE	41	Removal and Installation	64
MOONROOF	41	REAR SUNROOF GLASS	67
MOONROOF : Diagnosis Procedure	41	Exploded View	67
SUNSHADE	41	Removal and Installation	67
SUNSHADE : Diagnosis Procedure	41	WIND DEFLECTOR	70
RETAINED POWER OPERATION DOES NOT OPERATE PROPERLY	42	Exploded View	70
Diagnosis Procedure	42	Removal and Installation	70
		SUNSHADE	72
		Exploded View	72
		Removal and Installation	72
		MOONROOF SWITCH	74
		Removal and Installation	74

PRECAUTIONS

< PRECAUTION >

PRECAUTION

PRECAUTIONS

Precaution for Supplemental Restraint System (SRS) "AIR BAG" and "SEAT BELT PRE-TENSIONER"

INFOID:000000012166769

The Supplemental Restraint System such as "AIR BAG" and "SEAT BELT PRE-TENSIONER", used along with a front seat belt, helps to reduce the risk or severity of injury to the driver and front passenger for certain types of collision. Information necessary to service the system safely is included in the SR and SB section of this Service Manual.

WARNING:

- To avoid rendering the SRS inoperative, which could increase the risk of personal injury or death in the event of a collision which would result in air bag inflation, all maintenance must be performed by an authorized NISSAN/INFINITI dealer.
- Improper maintenance, including incorrect removal and installation of the SRS, can lead to personal injury caused by unintentional activation of the system. For removal of Spiral Cable and Air Bag Module, see the SR section.
- Do not use electrical test equipment on any circuit related to the SRS unless instructed to in this Service Manual. SRS wiring harnesses can be identified by yellow and/or orange harnesses or harness connectors.

PRECAUTIONS WHEN USING POWER TOOLS (AIR OR ELECTRIC) AND HAMMERS

WARNING:

- When working near the Airbag Diagnosis Sensor Unit or other Airbag System sensors with the Ignition ON or engine running, DO NOT use air or electric power tools or strike near the sensor(s) with a hammer. Heavy vibration could activate the sensor(s) and deploy the air bag(s), possibly causing serious injury.
- When using air or electric power tools or hammers, always switch the Ignition OFF, disconnect the battery and wait at least three minutes before performing any service.

Procedure without Cowl Top Cover

INFOID:000000012166770

When performing the procedure after removing cowl top cover, cover the lower end of windshield with urethane, etc. to prevent damage to the windshield.

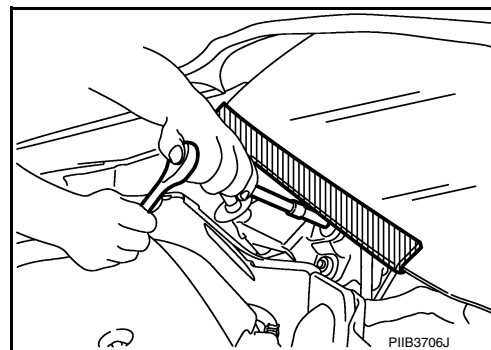

Precaution for Work

INFOID:000000012166771

- When removing or disassembling each component, be careful not to damage or deform it. If a component may be subject to interference, be sure to protect it with a shop cloth.
- When removing (disengaging) components with a screwdriver or similar tool, be sure to wrap the component with a shop cloth or vinyl tape to protect it.
- Protect the removed parts with a shop cloth and prevent them from being dropped.
- Replace a deformed or damaged clip.
- If a part is specified as a non-reusable part, always replace it with a new one.
- Be sure to tighten bolts and nuts securely to the specified torque.
- After installation is complete, be sure to check that each part works properly.
- Follow the steps below to clean components:
 - Water soluble dirt:
 - Dip a soft cloth into lukewarm water, wring the water out of the cloth and wipe the dirty area.
 - Then rub with a soft, dry cloth.
 - Oily dirt:

PRECAUTIONS

< PRECAUTION >

- Dip a soft cloth into lukewarm water with mild detergent (concentration: within 2 to 3%) and wipe the dirty area.
- Then dip a cloth into fresh water, wring the water out of the cloth and wipe the detergent off.
- Then rub with a soft, dry cloth.
- Do not use organic solvent such as thinner, benzene, alcohol or gasoline.
- For genuine leather seats, use a genuine leather seat cleaner.

PREPARATION

< PREPARATION >

PREPARATION

PREPARATION

Special Service Tool

INFOID:000000012166772

The actual shape of the tools may differ from those illustrated here.

Tool number (TechMate No.) Tool name	Description
— (J-39570) Chassis Ear	Locating the noise
— (J-50397) NISSAN Squeak and Rattle Kit	Repairing the cause of noise
— (J-46534) Trim Tool Set	Removing trim components

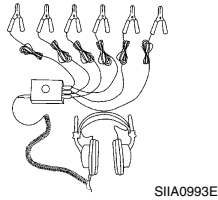

SIIA0993E



ALJIA1232ZZ

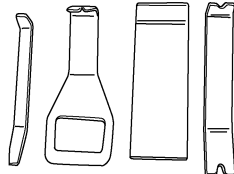

AWJIA0483ZZ

Commercial Service Tools

INFOID:000000012166773

(TechMate No.) Tool name	Description
(J-39565) Engine Ear	Locating the noise
(—) Power tool	Loosening nuts, screws and bolts

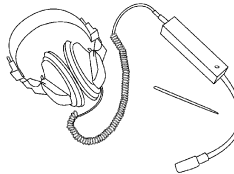

SIIA0995E



PIIB1407E

CLIP LIST







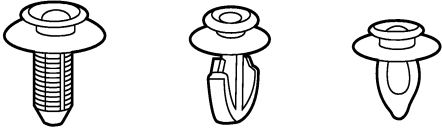

< PREPARATION >

CLIP LIST

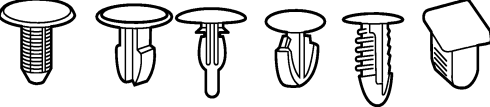
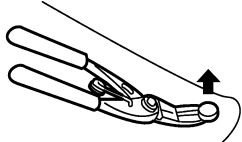
Descriptions for Clips

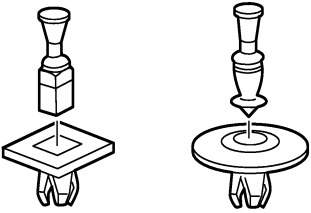
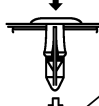
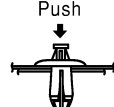
INFOID:000000012511776

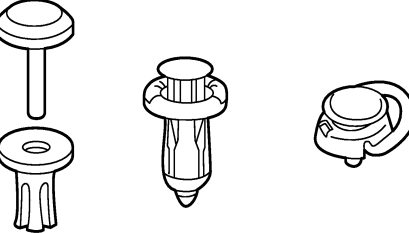
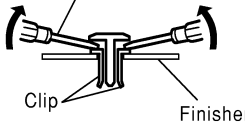

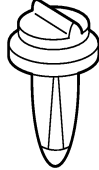
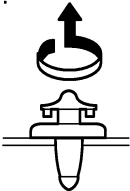





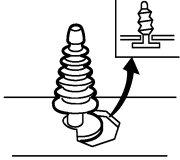
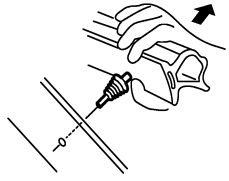

Replace any clips which are damaged during removal or installation.

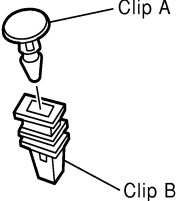
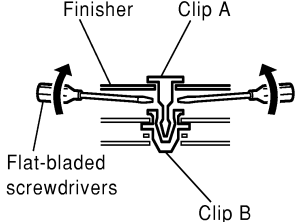
Symbol No.	Shapes	Removal & Installation
<p>C101</p> 		<p>Removal: Remove by bending up with flat-bladed screwdrivers or clip remover.</p> 
<p>C103</p> 		 <p>Removal: Remove with a clip remover.</p>
<p>C203</p> 		<p>Removal: Push center pin to catching position. (Do not remove center pin by hitting it.)</p> <p>Push</p>  <p>Installation:</p> 
<p>C205</p> 		<p>Removal:</p> 
<p>C206</p> 		<p>Removal:</p> 

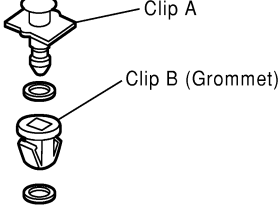
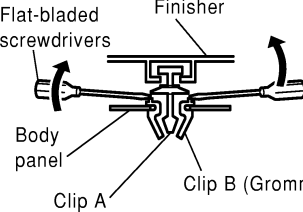
SIIA0315E

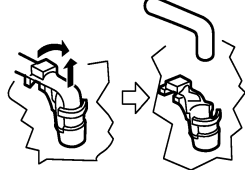
CLIP LIST

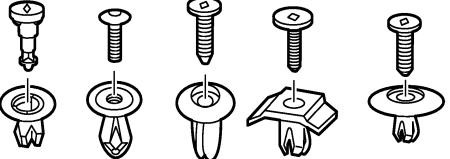
< PREPARATION >









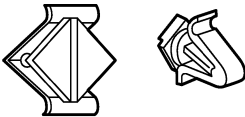

Symbol No.	Shapes	Removal & Installation
<p>CE103</p> 		<p>Removal:</p> 
<p>CF110</p> 		<p>Removal:</p> 
<p>CF118</p> 		<p>Removal:</p> 
<p>CR103</p> 		<p>Removal: Holder portion of clip must be spread out to remove rod.</p> 
<p>CS101</p> 		<p>Removal:</p> <ol style="list-style-type: none"> 1. Screw out with a Phillips screwdriver. 2. Remove female portion with flat-bladed screwdriver. 

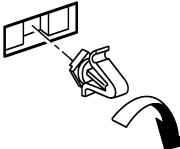
SIIA0316E

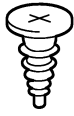
A
B
C
D
E
F
G
H
I
J
RF
L
M
N
O
P

CLIP LIST

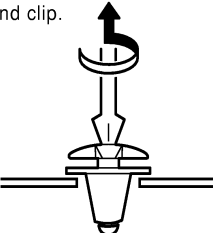

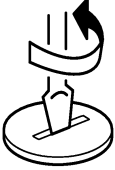
< PREPARATION >

Symbol No.	Shapes	Removal & Installation	
CG101 		Removal:  Rotate 45° to remove	Installation: 
CS102 			
CS113 		Removal: Disconnect upper connection of clip with a flat-bladed screwdriver, then remove clip while inserting a flat-bladed screwdriver between body panel and clip. 	
C111 			

SIIA0317E

CLIP LIST

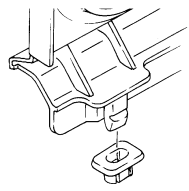
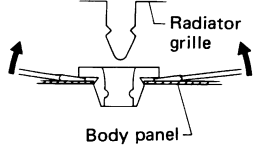
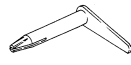
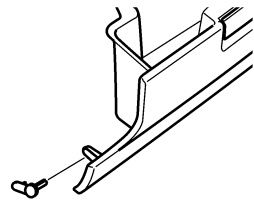
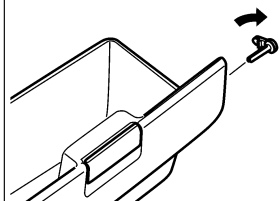
< PREPARATION >

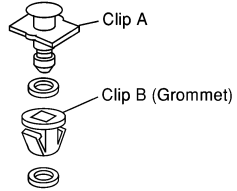
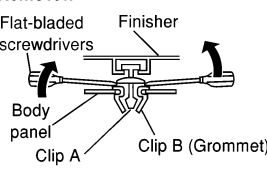
Symbol No.	Shapes	Removal & Installation
<p>CG104</p> 		<p>Removal: Remove by bending up with flat-bladed screwdrivers.</p> 
<p>CE114</p> 		
<p>CF118</p> 		<p>Removal: Flat-bladed screwdrivers</p> 

ALJIA0564GB

A
B
C
D
E
F
G
H
I
J
RF
L
M
N
O
P

COMPONENT PARTS

< SYSTEM DESCRIPTION >

SYSTEM DESCRIPTION

COMPONENT PARTS

Component Parts Location

INFOID:000000012166774

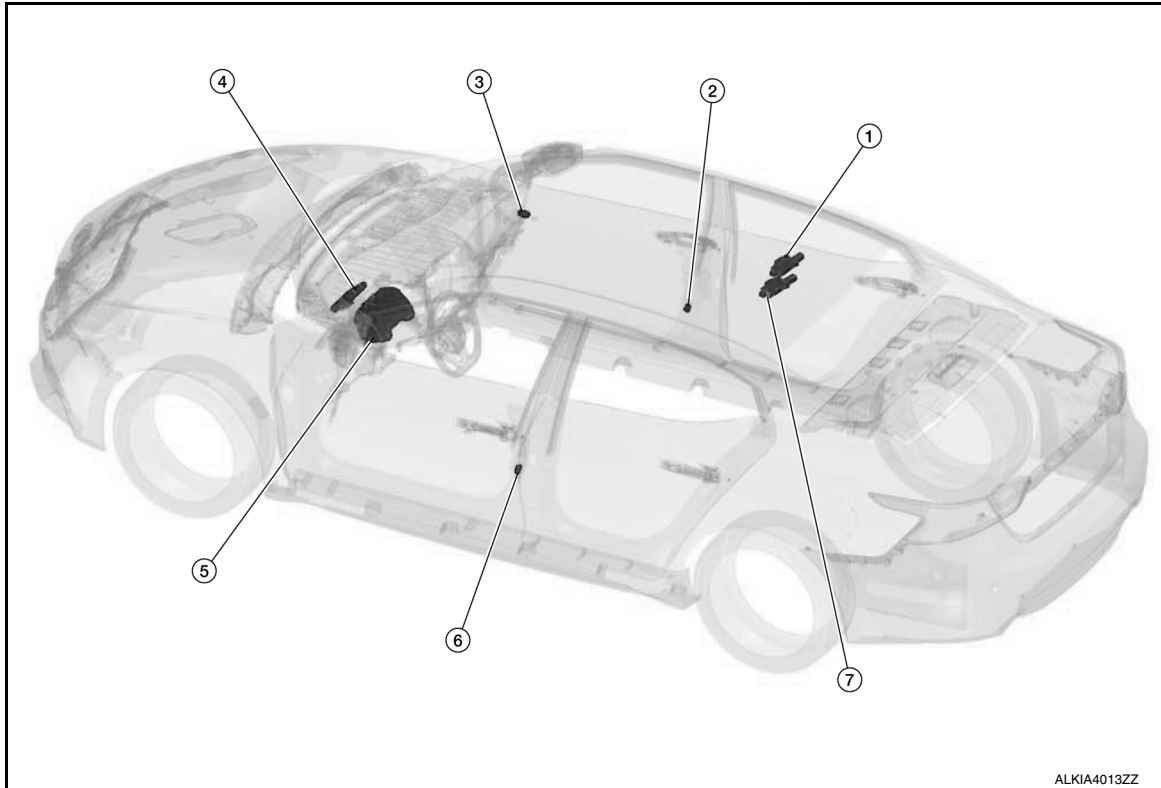

ALKIA4013ZZ

Component Description

INFOID:000000012166775

No.	Component	Function
1.	Sunshade motor assembly	Refer to RF-11, "Sunshade Motor Assembly" .
2.	Front door switch RH	Detects door open/close condition and transmits to BCM. Refer to DLK-17, "Front Door Switch" for detailed installation information.
3.	Moonroof switch	Refer to RF-11, "Moonroof Switch" .
4.	BCM	Supplies the power supply to the moonroof & sunshade motor assembly. Refer to BCS-5, "BODY CONTROL SYSTEM : Component Parts Location" for detailed installation information.
5.	Combination meter	Transmits the vehicle speed signal to BCM via CAN communication. Refer to MWI-5, "METER SYSTEM : Component Parts Location" for detailed installation information.
6.	Front door switch LH	Detects door open/close condition and transmits to BCM. Refer to DLK-17, "Front Door Switch" for detailed installation information.
7.	Moonroof motor assembly	Refer to RF-11, "Moonroof Motor Assembly" .

COMPONENT PARTS

< SYSTEM DESCRIPTION >

Moonroof Switch

INFOID:000000012166776

- Transmits tilt up/slide close and tilt down/slide open signal to moonroof motor and sunshade motor assemblies.

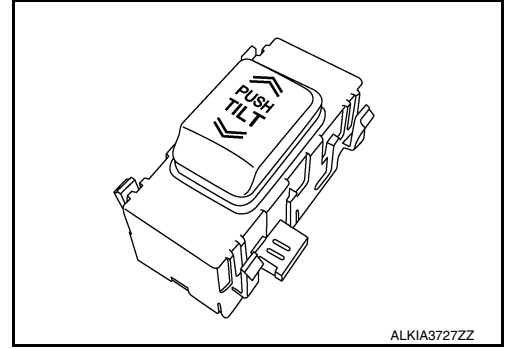

Moonroof Motor Assembly

INFOID:000000012166777

- Moonroof motor and CPU are integrated in moonroof motor assembly.
- Moonroof motor assembly operates moonroof to tilt up/down or slide open/close by sunroof switch operation.

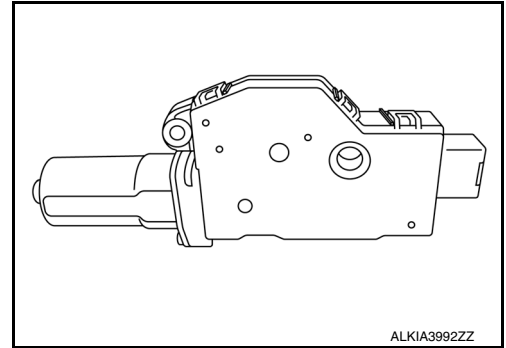

Sunshade Motor Assembly

INFOID:000000012166778

- Activated with a signal from the sunshade switch.

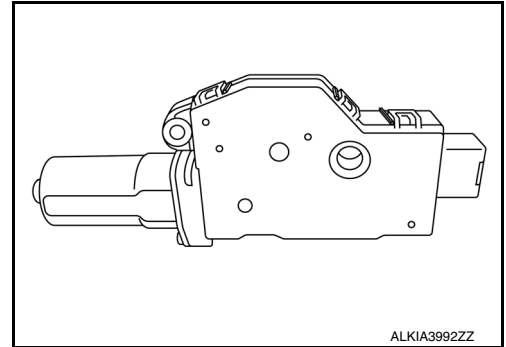

A
B
C
D
E
F
G
H
I
J
RF
L
M
N
O
P

SYSTEM

< SYSTEM DESCRIPTION >

SYSTEM MOONROOF

MOONROOF : System Diagram

INFOID:000000012166779

MOONROOF & SUNSHADE

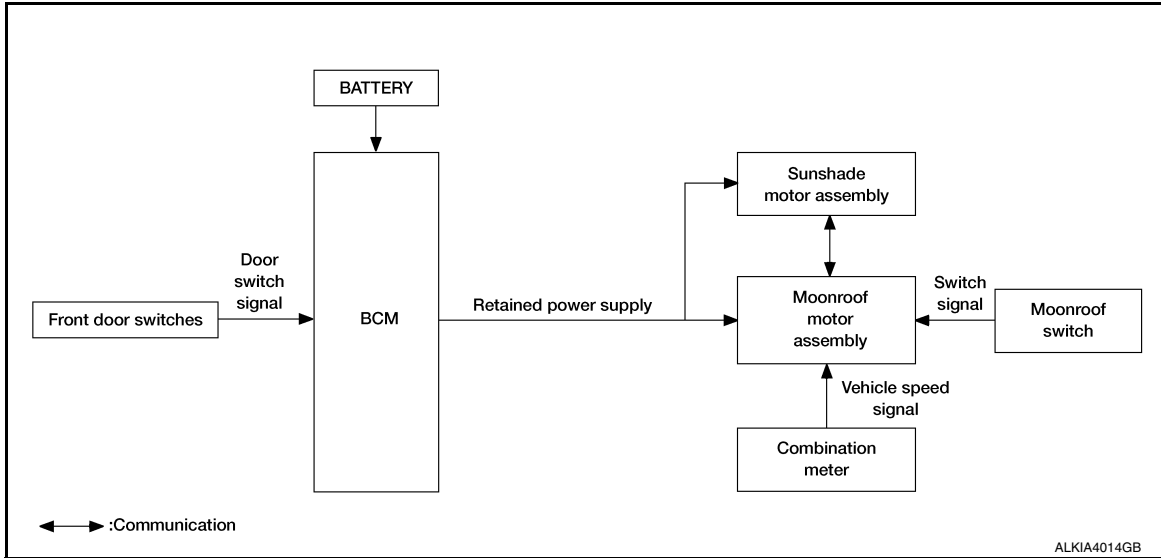

MOONROOF : System Description

INFOID:000000012166780

MOONROOF SYSTEM INPUT/OUTPUT SIGNAL CHART

Item	Input signal to moonroof motor assembly	Moonroof motor function	Actuator
Moonroof switch	Moonroof signal (tilt up/down or slide open/close)	Receives signal and moves the moonroof and sunshade assembly to the correct position.	Moonroof motor and/or Sunshade motor
	Sunshade signal (slide open/close)		
Combination meter	Vehicle speed signal	Receives speed signal and determines the amount of torque the motor requires.	
BCM	RAP signal	Retained power after the key is turned off and the front doors remain closed.	

MOONROOF AND SUNSHADE OPERATION

- The moonroof motor and sunshade motor assembly operates with the power supply that is output from the BCM while the ignition switch is ON or retained power is operating.
- Tilt up/down & slide open/close signals from the moonroof switch enable the moonroof motor and sunshade motor to move.
- Moonroof motor assembly receives a vehicle speed signal from the combination meter and controls the moonroof motor torque of tilt down at the time of high speed operation.

AUTO OPERATION

Moonroof and sunshade AUTO feature makes it possible to slide open and slide closed the moonroof and sunshade without holding the moonroof switch in the slide open/close position.

RETAINED POWER OPERATION

- Retained power operation is an additional power supply function that enables the moonroof and sunshade system to operate for 45 seconds after the ignition switch is turned off and the front doors remain closed.

Retained power function cancel conditions:

SYSTEM

< SYSTEM DESCRIPTION >

- Door CLOSE (door switch OFF)→OPEN (door switch ON).
- When ignition switch is ON again.
- When timer time passes (45 seconds).

A

ANTI-PINCH FUNCTION

The moonroof and sunshade motor's built in CPU monitors the moonroof motor and sunshade motor operation and position.

B

If a restriction is detected during the slide closed operation the moonroof/sunshade motor will move the glass/sunshade into the open positions.

C

D

E

F

G

H

I

J

RF

L

M

N

O

P

DIAGNOSIS SYSTEM (BCM)

< SYSTEM DESCRIPTION >

DIAGNOSIS SYSTEM (BCM) COMMON ITEM

COMMON ITEM : CONSULT Function (BCM - COMMON ITEM)

INFOID:000000012196340

APPLICATION ITEM

CONSULT performs the following functions via CAN communication with BCM.

Direct Diagnostic Mode	Description
ECU Identification	The BCM part number is displayed.
Self Diagnostic Result	The BCM self diagnostic results are displayed.
Data Monitor	The BCM input/output data is displayed in real time.
Active Test	The BCM activates outputs to test components.
Work support	The settings for BCM functions can be changed.
Configuration	<ul style="list-style-type: none"> The vehicle specification can be read and saved. The vehicle specification can be written when replacing BCM.
CAN Diag Support Mntr	The result of transmit/receive diagnosis of CAN communication is displayed.

SYSTEM APPLICATION

BCM can perform the following functions:

System	Sub System	Direct Diagnostic Mode						
		ECU Identification	Self Diagnostic Result	Data Monitor	Active Test	Work support	Configuration	CAN Diag Support Mntr
Door lock	DOOR LOCK		×	×	×	×		
Rear window defogger	REAR DEFOGGER			×	×	×		
Warning chime	BUZZER			×	×			
Interior room lamp timer	INT LAMP			×	×	×		
Exterior lamp	HEADLAMP			×	×	×		
Wiper and washer	WIPER			×	×	×		
Turn signal and hazard warning lamps	FLASHER			×	×	×		
Air conditioner	AIR CONDITIONER			×				
Intelligent Key system	INTELLIGENT KEY		×	×	×	×		
Combination switch	COMB SW			×				
BCM	BCM	×	×			×	×	×
Immobilizer	IMMU		×	×	×			
Interior room lamp battery saver	BATTERY SAVER			×	×			
Trunk	TRUNK			×				
Vehicle security system	THEFT ALM			×	×	×		
RAP system	RETAINED PWR			×				
Signal buffer system	SIGNAL BUFFER			×	×			
TPMS	AIR PRESSURE MONITOR		×	×	×			

FREEZE FRAME DATA (FFD)

DIAGNOSIS SYSTEM (BCM)

< SYSTEM DESCRIPTION >

The BCM records the following vehicle condition at the time a particular DTC is detected, and displays it on CONSULT.

CONSULT screen item	Indication/Unit	Description
Vehicle Speed	km/h	Vehicle speed at the moment a particular DTC is detected
Odo/Trip Meter	km	Total mileage (Odometer value) at the moment a particular DTC is detected
Vehicle Condition	SLEEP>LOCK	While turning BCM status from low power consumption mode to normal mode (Power supply position is "LOCK"*).
	SLEEP>OFF	While turning BCM status from low power consumption mode to normal mode (Power supply position is "OFF".)
	LOCK>ACC	While turning power supply position from "LOCK"*to "ACC"
	ACC>ON	While turning power supply position from "ACC" to "IGN"
	RUN>ACC	While turning power supply position from "RUN" to "ACC" (Vehicle is stopped and selector lever is in P position.)
	CRANK>RUN	While turning power supply position from "CRANKING" to "RUN" (From cranking up the engine to run it)
	RUN>URGENT	While turning power supply position from "RUN" to "ACC" (Emergency stop operation)
	ACC>OFF	While turning power supply position from "ACC" to "OFF"
	OFF>LOCK	While turning power supply position from "OFF" to "LOCK"*
	OFF>ACC	While turning power supply position from "OFF" to "ACC"
	ON>CRANK	While turning power supply position from "IGN" to "CRANKING"
	OFF>SLEEP	While turning BCM status from normal mode (Power supply position is "OFF".) to low power consumption mode
	LOCK>SLEEP	While turning BCM status from normal mode (Power supply position is "LOCK"*.) to low power consumption mode
	LOCK	Power supply position is "LOCK" (Ignition switch OFF)*
	OFF	Power supply position is "OFF" (Ignition switch OFF)
	ACC	Power supply position is "ACC" (Ignition switch ACC)
	ON	Power supply position is "IGN" (Ignition switch ON with engine stopped)
ENGINE RUN	Power supply position is "RUN" (Ignition switch ON with engine running)	
CRANKING	Power supply position is "CRANKING" (At engine cranking)	
IGN Counter	0 - 39	<p>The number of times that ignition switch is turned ON after DTC is detected</p> <ul style="list-style-type: none"> • The number is 0 when a malfunction is detected now. • The number increases like 1 → 2 → 3...38 → 39 after returning to the normal condition whenever ignition is switched OFF → ON. • The number is fixed to 39 until the self-diagnosis results are erased if it is over 39.

NOTE:

*: Power supply position shifts to "LOCK" from "OFF", when ignition switch is in the OFF position, selector lever is in the P position, and any of the following conditions are met:

- Closing door
- Opening door
- Door is locked using door request switch
- Door is locked using Intelligent Key

The power supply position shifts to "ACC" when the push-button ignition switch (push switch) is pushed at "LOCK".

RETAINED PWR

RETAINED PWR : CONSULT Function (BCM - RETAINED PWR)

INFOID:0000000012196341

DATA MONITOR

DIAGNOSIS SYSTEM (BCM)

< SYSTEM DESCRIPTION >

Monitor Item [Unit]	Description
DOOR SW-DR [On/Off]	Indicates condition of front door switch LH
DOOR SW-AS [On/Off]	Indicates condition of front door switch RH

BCM (BODY CONTROL MODULE)

< ECU DIAGNOSIS INFORMATION >

ECU DIAGNOSIS INFORMATION

BCM (BODY CONTROL MODULE)

List of ECU Reference

INFOID:0000000012166783

ECU	Reference
BCM	BCS-31, "Reference Value"
	BCS-51, "Fail Safe"
	BCS-52, "DTC Inspection Priority Chart"
	BCS-53, "DTC Index"

A
B
C
D
E
F
G
H
I
J
RF
L
M
N
O
P

MOONROOF MOTOR ASSEMBLY

< ECU DIAGNOSIS INFORMATION >

MOONROOF MOTOR ASSEMBLY

Reference Value

INFOID:000000012166784

TERMINAL LAYOUT

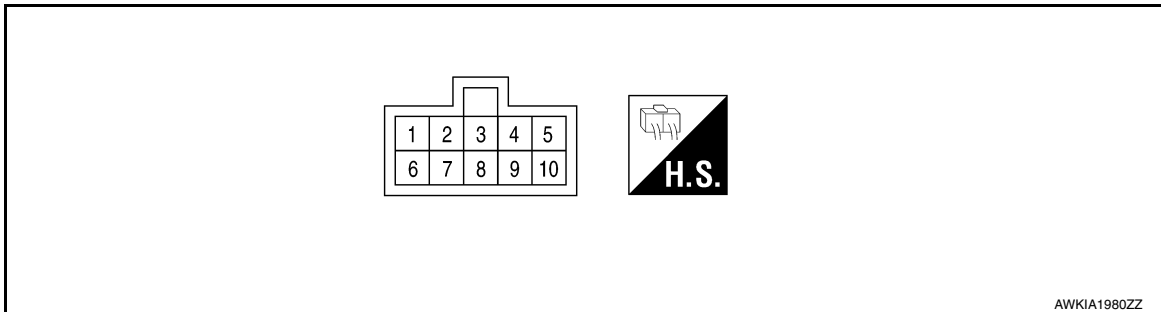

PHYSICAL VALUES

Terminal No. (Wire color)		Description		Condition	Voltage (Approx.)
+	-	Signal name	Input/ Output		
1 (B)	Ground	Ground	—	—	0
2 (W)	Ground	Double detent switch signal	Output	Moonroof switch in following position: • OPEN • CLOSE	0
3 (LG)	Ground	Ignition power supply	Input	Supplies power to moonroof motor assembly when ignition is in ON position.	Battery voltage
4 (R)	Ground	Moonroof push switch signal	Input	—	Battery voltage
5 (GR)	Ground	Open switch signal	Input	Moonroof switch in following position: • OPEN	0
6 (V)	Ground	Battery power supply	Input	—	Battery voltage
7 (B)	Ground	Motor communication	—	—	—
8 (G)	Ground	Vehicle speed signal (2-pulse)	Input	Speedometer operated [When vehicle speed is approx.40km/h (25MPH)]	<p>ELF1080D</p>
10 (BG)	Ground	Close switch signal	Input	Moonroof switch in following position: • CLOSE	0

SUNSHADE MOTOR ASSEMBLY

< ECU DIAGNOSIS INFORMATION >

SUNSHADE MOTOR ASSEMBLY

Reference Value

INFOID:000000012166785

TERMINAL LAYOUT

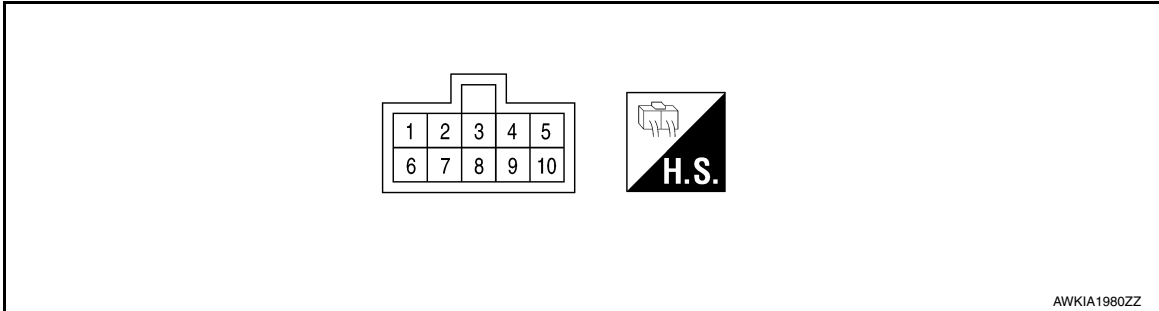

PHYSICAL VALUES

Terminal No. (Wire color)		Description		Condition	Voltage (Approx.)
+	-	Signal name	Input/ Output		
1 (B)	Ground	Ground	-	-	0
6 (V)	Ground	Battery power supply	Input	Supplies power to sun- shade motor.	Battery voltage
7 (B)	Ground	Serial communication	Input/ Output	Provides communication link between sunshade motor assembly and moonroof motor assembly	0

A
B
C
D
E
F
G
H
I
J
L
M
N
O
P

RF

MOONROOF SYSTEM

< WIRING DIAGRAM >

WIRING DIAGRAM

MOONROOF SYSTEM

Wiring Diagram

INFOID:000000012166786

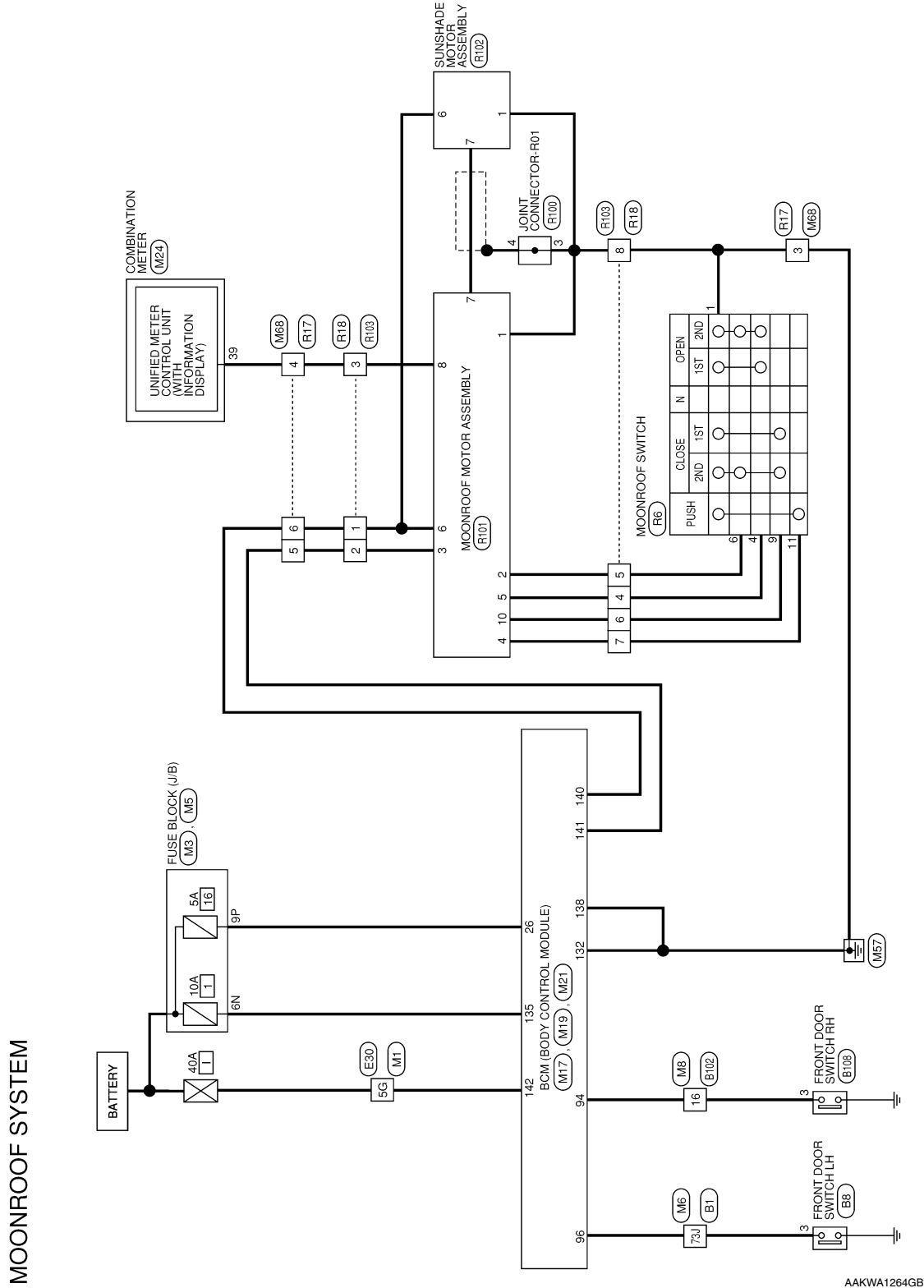

MOONROOF SYSTEM

< WIRING DIAGRAM >

MOONROOF SYSTEM CONNECTORS

Connector No.	M1
Connector Name	WIRED TO WIRE
Connector Type	TH80FW-CS16-TM4
Connector Color	WHITE

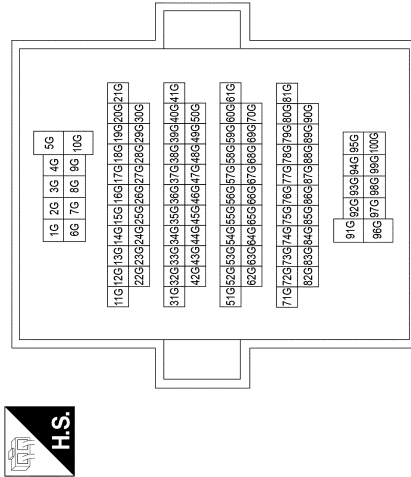

Terminal No.	5G	Color of Wire	W	Signal Name	-
--------------	----	---------------	---	-------------	---

Connector No.	M3
Connector Name	FUSE BLOCK (J/B)
Connector Type	CS06FW-M2
Connector Color	WHITE

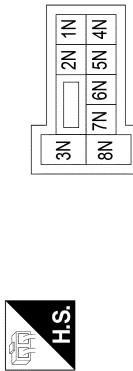

Terminal No.	6N	Color of Wire	LG	Signal Name	-
--------------	----	---------------	----	-------------	---

Connector No.	M5
Connector Name	FUSE BLOCK (J/B)
Connector Type	NS16FW-CS
Connector Color	WHITE

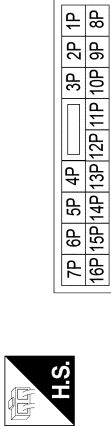

Terminal No.	9P	Color of Wire	Y	Signal Name	-
--------------	----	---------------	---	-------------	---

Connector No.	M6
Connector Name	WIRED TO WIRE
Connector Type	TH80FDGY-CS16-TM4
Connector Color	GRAY

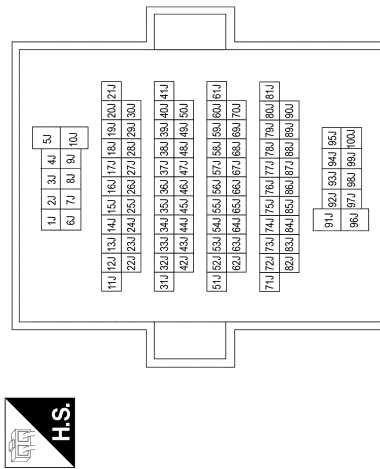

Terminal No.	73J	Color of Wire	P	Signal Name	-
--------------	-----	---------------	---	-------------	---

Connector No.	M8
Connector Name	WIRED TO WIRE
Connector Type	TH32FW-NH
Connector Color	WHITE

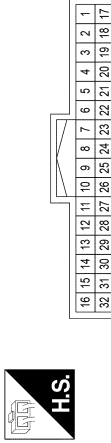

Terminal No.	16	Color of Wire	W	Signal Name	-
--------------	----	---------------	---	-------------	---

Connector No.	M17
Connector Name	BCM (BODY CONTROL MODULE)
Connector Type	FEA09FW-FHAG-SA
Connector Color	WHITE

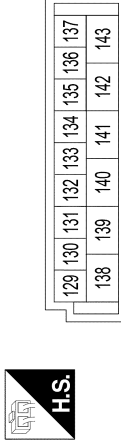

Terminal No.	Color of Wire	Signal Name
132	B	GND2
135	LG	BAT BCM FUSE
138	B	GND1
140	V	P/W POWER SUPPLY BAT
141	LG	P/W POWER SUPPLY IGN
142	W	BAT-POWER F/L

A
B
C
D
E
F
G
H
I
J
K
L
M
N
O
P

RF

MOONROOF SYSTEM

< WIRING DIAGRAM >

Connector No.	B1
Connector Name	WIRE TO WIRE
Connector Type	TH80MDGY-CS16-TM4
Connector Color	GRAY

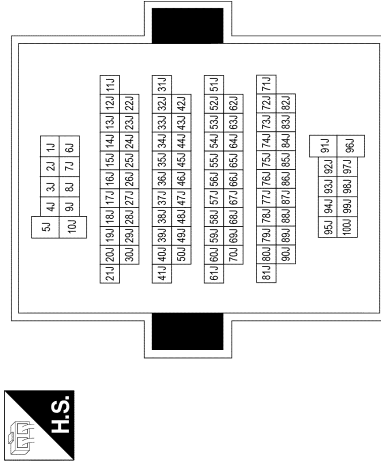

Terminal No.	73J	Color of Wire	BR	Signal Name	-
--------------	-----	---------------	----	-------------	---

Connector No.	B8
Connector Name	FRONT DOOR SWITCH LH
Connector Type	TH40FW-NH
Connector Color	WHITE

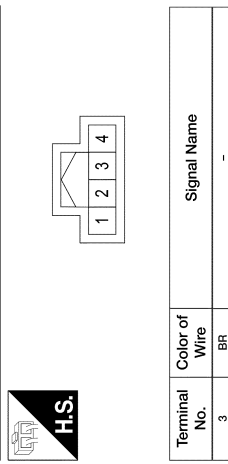

Terminal No.	3	Color of Wire	BR	Signal Name	-
--------------	---	---------------	----	-------------	---

Connector No.	M68
Connector Name	WIRE TO WIRE
Connector Type	NS06MW-CS
Connector Color	WHITE

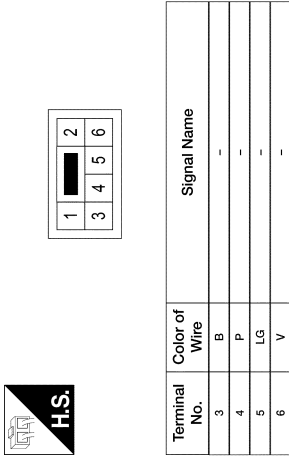

Terminal No.	3	Color of Wire	B	Signal Name	-
4	P	-	-	-	-
5	LG	-	-	-	-
6	V	-	-	-	-

Connector No.	E30
Connector Name	WIRE TO WIRE
Connector Type	TH80MW-CS16-TM4
Connector Color	WHITE

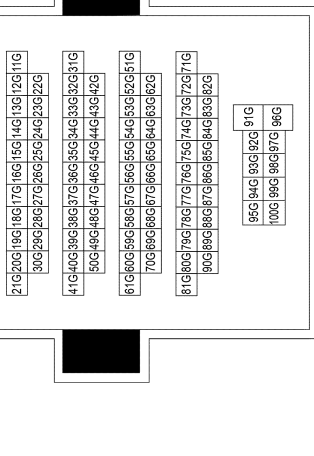

Terminal No.	5G	Color of Wire	P	Signal Name	-
--------------	----	---------------	---	-------------	---

Connector No.	M19
Connector Name	BCM (BODY CONTROL MODULE)
Connector Type	TH24FGY-NH
Connector Color	GRAY

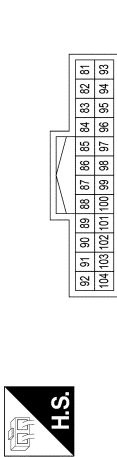

Terminal No.	94	Color of Wire	W	Signal Name	AS DOOR SW
96	P	-	-	-	DR DOOR SW

Connector No.	M21
Connector Name	BCM (BODY CONTROL MODULE)
Connector Type	TH40FG-NH
Connector Color	GREEN

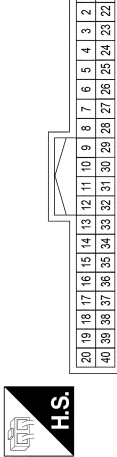

Terminal No.	26	Color of Wire	Y	Signal Name	SHORTING INPUT
--------------	----	---------------	---	-------------	----------------

Connector No.	M24
Connector Name	COMBINATION METER
Connector Type	TH40FW-NH
Connector Color	WHITE

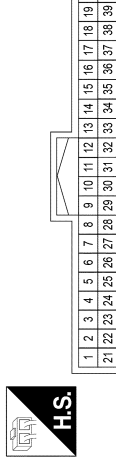

Terminal No.	39	Color of Wire	P	Signal Name	SPEED 2P/R OUT
--------------	----	---------------	---	-------------	----------------

AAK1A3046GB

MOONROOF SYSTEM

< WIRING DIAGRAM >

Connector No.	R100
Connector Name	JOINT CONNECTOR-R01
Connector Type	TK04FW-J
Connector Color	WHITE

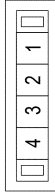

Terminal No.	Color of Wire	Signal Name
3	GR	-
4	SHIELD	-

Connector No.	R101
Connector Name	MOONROOF MOTOR ASSEMBLY
Connector Type	YEA10FGY
Connector Color	GRAY

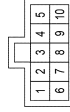

Terminal No.	Color of Wire	Signal Name
1	B	-
2	W	-
3	LG	-
4	R	-
5	GR	-
6	Y	-
7	B	-
8	G	-
10	BG	-

Connector No.	R17
Connector Name	WIRE TO WIRE
Connector Type	NS06FW-CS
Connector Color	WHITE

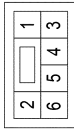

Terminal No.	Color of Wire	Signal Name
3	B	-
4	L/B	-
5	R/Y	-
6	L/W	-

Connector No.	R18
Connector Name	WIRE TO WIRE
Connector Type	NS08FW-CS
Connector Color	WHITE

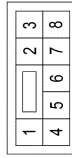

Terminal No.	Color of Wire	Signal Name
1	L/W	-
2	R/Y	-
3	L/B	-
4	Y	-
5	G	-
6	LG	-
7	W/R	-
8	B	-

Connector No.	B102
Connector Name	WIRE TO WIRE
Connector Type	TH32MW-NH
Connector Color	WHITE

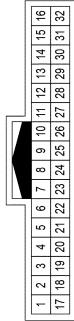

Terminal No.	Color of Wire	Signal Name
16	SB	-

Connector No.	B108
Connector Name	FRONT DOOR SWITCH RH
Connector Type	TH04FW-NH
Connector Color	WHITE

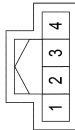

Terminal No.	Color of Wire	Signal Name
3	SB	-

Connector No.	R6
Connector Name	MOONROOF SWITCH
Connector Type	TH12FW-NH
Connector Color	WHITE

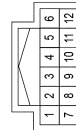

Terminal No.	Color of Wire	Signal Name
1	B	-
4	Y	-
6	G	-
9	LG	-
11	W/R	-

AAKIA3047GB

A
B
C
D
E
F
G
H
I
J
RF
L
M
N
O
P

MOONROOF SYSTEM

< WIRING DIAGRAM >

Connector No.	R102
Connector Name	SUNSHADE MOTOR ASSEMBLY
Connector Type	YEA10FGY
Connector Color	GRAY

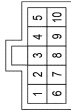

Terminal No.	Color of Wire	Signal Name
1	B	-
6	V	-
7	B	-

Connector No.	R103
Connector Name	WIRE TO WIRE
Connector Type	NS08MM-CS
Connector Color	WHITE

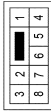

Terminal No.	Color of Wire	Signal Name
1	V	-
2	LG	-
3	G	-
4	GR	-
5	W	-
6	BG	-
7	R	-
8	B	-

AAKIA3048GB

DIAGNOSIS AND REPAIR WORKFLOW

< BASIC INSPECTION >

BASIC INSPECTION

DIAGNOSIS AND REPAIR WORKFLOW

Work Flow

INFOID:000000012166787

OVERALL SEQUENCE

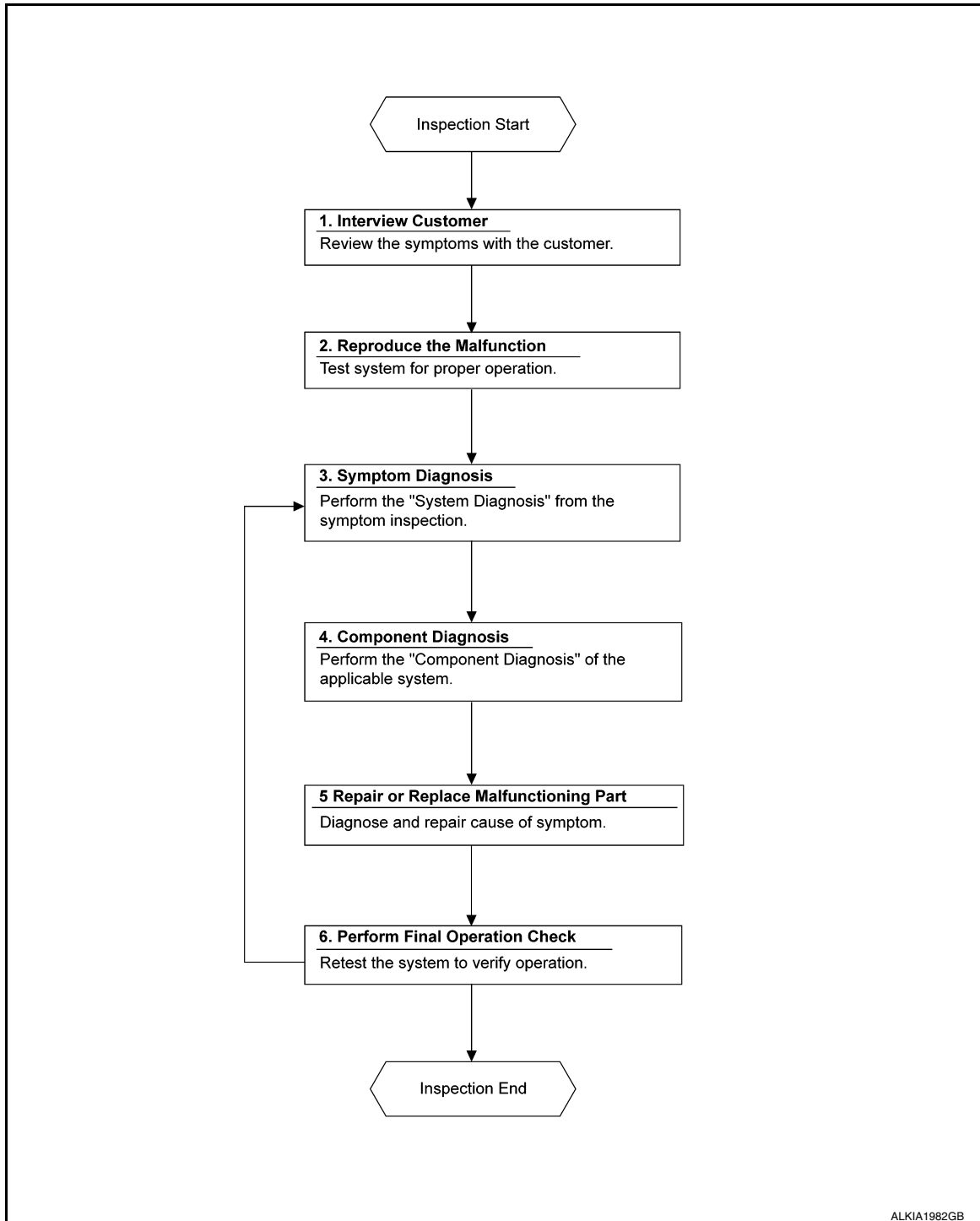

DETAILED FLOW

1. INTERVIEW CUSTOMER

Interview the customer to obtain as much information as possible about the conditions and environment under which the malfunction occurred.

A
B
C
D
E
F
G
H
I
J
RF
L
M
N
O
P

DIAGNOSIS AND REPAIR WORKFLOW

< BASIC INSPECTION >

>> GO TO 2.

2. REPRODUCE THE MALFUNCTION

Reproduce the malfunction on the vehicle that the customer describes.
Inspect the relation of the symptoms and the condition when the symptoms occur.

>> GO TO 3.

3. SYMPTOM DIAGNOSIS

Use Symptom diagnosis from the symptom inspection result in step 2 and then identify where to start performing the diagnosis based on possible causes and symptoms.

>> GO TO 4.

4. COMPONENT DIAGNOSIS

Perform the diagnosis with Component diagnosis of the applicable system.

>> GO TO 5.

5. REPAIR OR REPLACE THE MALFUNCTIONING PART

Repair or replace the specified malfunctioning parts.

>> GO TO 6.

6. PERFORM FINAL OPERATIONAL CHECK

Check that malfunctions are not reproduced when obtaining the malfunction information from the customer, referring to the symptom inspection result in step 2.

Are the malfunctions corrected?

YES >> Inspection End.

NO >> GO TO 3.

INSPECTION AND ADJUSTMENT

< BASIC INSPECTION >

INSPECTION AND ADJUSTMENT

ADDITIONAL SERVICE WHEN REPLACING CONTROL UNIT

ADDITIONAL SERVICE WHEN REPLACING CONTROL UNIT : Special Repair Requirement

INFOID:000000012166788

Initialization of system should be conducted after the following conditions:

- When the moonroof motor or sunshade motor is changed.
- When the moonroof motor or sunshade does not operate normally (incomplete initialization conditions).

INITIALIZATION PROCEDURE

Moonroof

If the moonroof or sunshade does not close or open automatically, use the following process to return moonroof or sunshade operation to normal:

1. Press and hold either the first or second detent of the close switch until both glass and shade reach the hard stop and bounce back.
2. Following the bounce back, release and reactivate the close switch (either 1st or 2nd detent) within 5 seconds.
3. The glass and shade will cycle to full open and back to flush. Hold the switch until both have completed their movement.
4. Release the close switch, initialization is complete if the moonroof and sunshade both operated normally.

ANTI-PINCH FUNCTION

1. Fully open the moonroof.
2. Place a piece of wood near the fully closed position.
3. Close the moonroof completely with auto-slide close function.
4. Check that moonroof lowers for approximately 150mm (5.91 in) or 2 seconds without pinching a piece of wood and stop.
5. Fully open sunshade.
6. Place a piece of wood near fully closed position.
7. Close the sunshade completely with the auto slide close.
8. Check that sunshade lowers for approximately 150mm (5.91 in) or 2 seconds without pinching a piece of wood and stop.

CAUTION:

- **Do not test the anti-pinch function with your hands or other body parts because they may be pinched.**
- **Depending on the environment and driving conditions, if a similar impact or load is applied to the moonroof it may lower.**
- **Test the auto-slide operation before inspection when the initialization procedure is performed.**
- **Perform the initialization procedure when the auto-slide operation or anti-pinch function does not operate normally.**

POWER SUPPLY AND GROUND CIRCUIT

< DTC/CIRCUIT DIAGNOSIS >

DTC/CIRCUIT DIAGNOSIS

POWER SUPPLY AND GROUND CIRCUIT BODY CONTROL SYSTEM

BODY CONTROL SYSTEM : Diagnosis Procedure

INFOID:0000000012233761

Regarding Wiring Diagram information, refer to [BCS-56, "Wiring Diagram"](#).

1. CHECK FUSE AND FUSIBLE LINK

Check if the following BCM fuses or fusible link are blown.

Signal name	Fuse and fusible link No.
Fusible link battery power	I (40A)
BCM battery fuse	1 (10A)

Is the fuse or fusible link blown?

- YES >> Replace the blown fuse or fusible link after repairing the affected circuit.
NO >> GO TO 2.

2. CHECK POWER SUPPLY CIRCUIT

1. Turn ignition switch OFF.
2. Disconnect BCM connector M17.
3. Check voltage between BCM harness connector M17 and ground.

Terminals		Voltage (Approx.)
(+)	(-)	
BCM		Ground
Connector	Terminal	
M17	135	
	142	Battery voltage

Is the measurement normal?

- YES >> GO TO 3.
NO >> Repair or replace harness.

3. CHECK GROUND CIRCUIT

Check continuity between BCM harness connector M17 and ground.

BCM		Ground	Continuity
Connector	Terminal		
M17	138		Yes
	132		

Is the inspection result normal?

- YES >> Inspection End.
NO >> Repair or replace harness.

MOONROOF MOTOR ASSEMBLY

MOONROOF MOTOR ASSEMBLY : Description

INFOID:0000000012166790

- BCM supplies the moonroof motor assembly with power.
- CPU is integrated in moonroof motor assembly.

POWER SUPPLY AND GROUND CIRCUIT

< DTC/CIRCUIT DIAGNOSIS >

- Tilts up/down & slides open/close by moonroof switch operation.
- In order to close the moonroof during high speed driving, the Combination meter will send a speed signal to the moonroof CPU to adjust the torque of the motor during the tilt-down operation.

MOONROOF MOTOR ASSEMBLY : Component Function Check

INFOID:000000012166791

1. CHECK MOONROOF MOTOR FUNCTION

Does the tilt up/down & slide open/close functions operate normally with moonroof switch?

Is the inspection result normal?

YES >> Moonroof motor assembly is OK.

NO >> Refer to [RF-29, "MOONROOF MOTOR ASSEMBLY : Diagnosis Procedure"](#).

MOONROOF MOTOR ASSEMBLY : Diagnosis Procedure

INFOID:000000012166792

Regarding Wiring Diagram information, refer to [RF-20, "Wiring Diagram"](#).

MOONROOF MOTOR ASSEMBLY

1. CHECK POWER SUPPLY CIRCUIT

1. Turn ignition switch OFF.
2. Disconnect the moonroof motor assembly connector.
3. Turn ignition switch ON.
4. Check voltage between moonroof motor assembly connector and ground.

(+)		(-)	Voltage (Approx.)
Moonroof motor assembly	Terminal		
R101	3	Ground	Battery voltage
	6		

Is the inspection result normal?

YES >> GO TO 2.

NO >> GO TO 3.

2. CHECK GROUND CIRCUIT

1. Turn ignition switch OFF.
2. Check continuity between moonroof motor assembly connector and ground.

Moonroof motor assembly	Terminal	Ground	Continuity
R101	1		

Is the inspection result normal?

YES >> GO TO 3.

NO >> Repair or replace harness.

3. CHECK MOONROOF SWITCH INPUT SIGNAL

1. Connect moonroof motor assembly.
2. Turn ignition switch ON.
3. Check voltage between the moonroof motor assembly connector and ground.

Moonroof motor as- sembly	Terminals		Condition	Voltage (Approx.)
	(+)	(-)		

POWER SUPPLY AND GROUND CIRCUIT

< DTC/CIRCUIT DIAGNOSIS >

R101	5	Ground	Moonroof switch is operated TILT DOWN or SLIDE OPEN	0
			Other than above	Battery voltage
	10		Moonroof switch is operated TILT UP or SLIDE CLOSE	0
			Other than above	Battery voltage

Is the inspection result normal?

YES >> GO TO 6.

NO >> GO TO 4.

4. CHECK MOONROOF SWITCH CIRCUIT

- Turn ignition switch OFF.
- Disconnect the moonroof motor assembly and moonroof switch.
- Check continuity between the moonroof motor assembly connector and moonroof switch connector.

Moonroof motor assembly	Terminal	Moonroof switch	Terminal	Continuity
R101	10	R6	9	Yes
	5		4	

- Check continuity between the moonroof motor assembly connector and ground.

Moonroof motor assembly	Terminal	Ground	Continuity
R101	10	Ground	No
	5		

Is the inspection result normal?

YES >> GO TO 5.

NO >> Repair or replace harness.

5. CHECK MOONROOF SWITCH GROUND CIRCUIT

- Connect moonroof motor assembly.
- Check continuity between the moonroof switch connector and ground.

Moonroof switch	Terminal	Ground	Continuity
R6	1	Ground	Yes

Is the inspection result normal?

YES >> Refer to [RF-34, "Component Inspection"](#).

NO >> Repair or replace harness.

6. CHECK COMBINATION METER SIGNAL

- Connect the moonroof motor assembly connector.
- Turn ignition switch ON.
- Check the signal between the moonroof motor assembly connector and ground with oscilloscope.

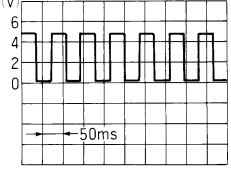
(+)		(-)	Condition	Signal (Reference value)
Moonroof motor assembly	Terminal	Ground		
R101	8	Ground	Speedometer operated [When vehicle speed is approx.40km/h (25MPH)]	 <p style="text-align: right;">ELF1080D</p>

Is the inspection result normal?

YES >> Replace moonroof motor assembly. Refer to [RF-52, "Removal and Installation"](#).

POWER SUPPLY AND GROUND CIRCUIT

< DTC/CIRCUIT DIAGNOSIS >

NO >> GO TO 7.

7. CHECK COMBINATION METER CIRCUIT

1. Turn ignition switch OFF.
2. Disconnect combination meter.
3. Check continuity between the combination meter connector and the moonroof motor assembly connector.

Combination meter	Terminal	Moonroof motor assembly	Terminal	Continuity
M24	39	R101	8	Yes

4. Check continuity between the combination meter connector and ground.

Combination meter connector	Terminal	Ground	Continuity
M24	39		No

Is the inspection result normal?

YES >> Replace combination meter. Refer to [MWI-68, "Removal and Installation"](#).

NO >> Repair or replace harness.

MOONROOF MOTOR ASSEMBLY : Special Repair Requirement

INFOID:0000000012166793

1. PERFORM INITIALIZATION PROCEDURE

Perform the initialization procedure.

Refer to [RF-31, "MOONROOF MOTOR ASSEMBLY : Special Repair Requirement"](#).

>> GO TO 2.

2. CHECK ANTI-PINCH OPERATION

Check the anti-pinch operation.

Refer to [RF-31, "MOONROOF MOTOR ASSEMBLY : Special Repair Requirement"](#).

Is the inspection result normal?

YES >> Inspection End.

NO >> Check fitting adjustment.

SUNSHADE MOTOR ASSEMBLY

SUNSHADE MOTOR ASSEMBLY : Description

INFOID:0000000012166794

- BCM supplies the sunshade motor assembly with power.
- CPU is integrated in sunshade motor assembly.
- Slide open/close controlled by the moonroof switch operation.

SUNSHADE MOTOR ASSEMBLY : Component Function Check

INFOID:0000000012166795

1. CHECK SUNSHADE MOTOR FUNCTION

Does the slide open and close functions operate normally with the moonroof switch?

Is the inspection result normal?

YES >> Sunshade motor assembly is OK.

NO >> Refer to [RF-31, "SUNSHADE MOTOR ASSEMBLY : Diagnosis Procedure"](#).

SUNSHADE MOTOR ASSEMBLY : Diagnosis Procedure

INFOID:0000000012166796

Regarding Wiring Diagram information, refer to [RF-20, "Wiring Diagram"](#).

1. CHECK POWER SUPPLY

1. Turn ignition switch OFF.

POWER SUPPLY AND GROUND CIRCUIT

< DTC/CIRCUIT DIAGNOSIS >

2. Disconnect sunshade motor assembly connector.
3. Turn ignition switch ON.
4. Check voltage between sunshade motor assembly harness connector and ground.

(+)		(-)	Voltage (Approx.)
Sunshade motor assembly			
Connector	Terminal		
R102	6	Ground	Battery voltage

Is the inspection result normal?

- YES >> GO TO 2.
 NO >> Repair or replace the harness.

2. CHECK GROUND CIRCUIT

1. Turn ignition switch OFF.
2. Check continuity between sunshade motor assembly harness connector and ground.

Sunshade motor assembly		Ground	Continuity
Connector	Terminal		
R102	1		Yes

Is the inspection result normal?

- YES >> Replace sunshade motor assembly. Refer to [RF-54. "Removal and Installation"](#).
 NO >> Repair or replace the harness.

MOONROOF SWITCH

< DTC/CIRCUIT DIAGNOSIS >

MOONROOF SWITCH

Description

INFOID:000000012166797

Transmits switch operation signal to moonroof motor and sunshade motor assembly.

Diagnosis Procedure

INFOID:000000012166798

Regarding Wiring Diagram information, refer to [RF-20, "Wiring Diagram"](#).

1. CHECK MOONROOF SWITCH INPUT SIGNAL

1. Turn ignition switch ON.
2. Check voltage between moonroof motor assembly harness connector and ground.

(+)		(-)	Condition	Voltage (Approx.)
Moonroof motor assembly				
Connector	Terminals			
R101	4	Ground	Moonroof switch is operated OPEN (1st)	0
			Other than above	Battery voltage
	10		Moonroof switch is operated CLOSE (2nd)	0
			Other than above	Battery voltage
	5		Moonroof switch is operated OPEN (2nd click to open sunshade)	0
			Other than above	Battery voltage
	2		Moonroof switch is operated CLOSE (2nd click to close sunshade)	0
			Other than above	Battery voltage

Is the inspection result normal?

YES >> Inspection End.

NO >> GO TO 2.

2. CHECK MOONROOF SWITCH CIRCUIT

1. Turn ignition switch OFF.
2. Disconnect moonroof motor assembly connector and moonroof switch connector.
3. Check continuity between moonroof motor assembly harness connector and moonroof switch harness connector.

Moonroof motor assembly		Moonroof switch		Continuity
Connector	Terminal	Connector	Terminal	
R101	4	R6	11	Yes
	10		9	
	5		4	
	2		6	

4. Check continuity between moonroof motor assembly harness connector and ground.

MOONROOF SWITCH

< DTC/CIRCUIT DIAGNOSIS >

Moonroof motor assembly		Ground	Continuity
Connector	Terminal		
R101	4	Ground	No
	10		
	5		
	2		

Is the inspection result normal?

YES >> GO TO 3.

NO >> Repair or replace the harness.

3. CHECK MOONROOF SWITCH GROUND CIRCUIT

Check continuity between moonroof switch harness connector and ground.

Moonroof switch		Ground	Continuity
Connector	Terminal		
R6	1		Yes

Is the inspection result normal?

YES >> GO TO 4.

NO >> Repair or replace the harness.

4. CHECK MOONROOF SWITCH

Check moonroof switch.

Refer to [RF-34, "Component Inspection"](#).

Is the inspection result normal?

YES >> GO TO 5.

NO >> Replace moonroof switch. Refer to [RF-74, "Removal and Installation"](#).

5. CHECK INTERMITTENT INCIDENT

Refer to [GI-41, "Intermittent Incident"](#).

>> Inspection End.

Component Inspection

INFOID:0000000012166799

MOONROOF SWITCH

1. CHECK MOONROOF SWITCH

1. Turn ignition switch OFF.
2. Disconnect moonroof switch.
3. Check continuity between moonroof switch terminals.

Terminals	Condition	Continuity
6	Moonroof switch is operated - CLOSED	Yes
	Other than above	No
4	Moonroof switch is operated - OPEN	Yes
	Other than above	No
9	Moonroof switch is operated - HOLD OPEN or HOLD CLOSE	Yes
	Other than above	No
11	Moonroof switch is operated - HOLD OPEN or HOLD CLOSE	Yes
	Other than above	No

Is the inspection result normal?

YES >> Moonroof switch is OK.

MOONROOF SWITCH

< DTC/CIRCUIT DIAGNOSIS >

NO >> Replace moonroof switch. Refer to [RF-74. "Removal and Installation"](#).

A

B

C

D

E

F

G

H

I

J

RF

L

M

N

O

P

DOOR SWITCH

< DTC/CIRCUIT DIAGNOSIS >

DOOR SWITCH

Component Function Check

INFOID:000000012242615

1.CHECK FUNCTION

CONSULT

1. Select "DOOR LOCK" of "BCM".
2. Select "DOOR SW-DR", "DOOR SW-AS", "DOOR SW-RL" or "DOOR SW-RR" in "Data Monitor" mode.
3. Check that the function operates normally according to the following conditions:

Monitor Item	Condition		Status
DOOR SW-DR	Front door LH	Open	On
		Closed	Off
DOOR SW-AS	Front door RH	Open	On
		Closed	Off
DOOR SW-RL	Rear door LH	Open	On
		Closed	Off
DOOR SW-RR	Rear door RH	Open	On
		Closed	Off

Is the inspection result normal?

- YES >> Door switch is OK.
 NO >> Refer to [RF-36, "Diagnosis Procedure"](#).

Diagnosis Procedure

INFOID:000000012242616

Regarding Wiring Diagram information, refer to [DLK-51, "Wiring Diagram"](#).

1.CHECK DOOR SWITCH INPUT SIGNAL

1. Turn ignition switch OFF.
2. Disconnect malfunctioning door switch connector.
3. Check signal between malfunctioning door switch harness connector and ground using oscilloscope.

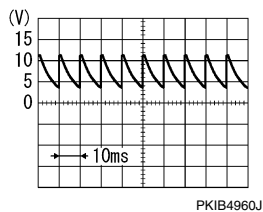
(+)		Terminal	(-)	Signal (Reference value)
Door switch				
Connector		3	Ground	
Front LH	B8			
Front RH	B108			
Rear LH	B18			
Rear RH	B116			

Is the inspection result normal?

- YES >> GO TO 3.
 NO >> GO TO 2.

2.CHECK DOOR SWITCH CIRCUIT

1. Disconnect BCM connector.
2. Check continuity between door switch harness connector and BCM harness connector.

DOOR SWITCH

< DTC/CIRCUIT DIAGNOSIS >

Door switch		BCM		Continuity
Connector	Terminal	Connector	Terminal	
Front LH	B8	3	M19	96
Front RH	B108			94
Rear LH	B18			82
Rear RH	B116			93

3. Check continuity between door switch harness connector and ground.

Door switch		Ground	Continuity
Connector	Terminal		
Front LH	B8	3	No
Front RH	B108		
Rear LH	B18		
Rear RH	B116		

Is the inspection result normal?

YES >> Replace BCM. Refer to [BCS-82, "Removal and Installation"](#).

NO >> Repair or replace harness.

3.CHECK DOOR SWITCH

Refer to [RF-37, "Component Inspection"](#).

Is the inspection result normal?

YES >> GO TO 4.

NO >> Replace malfunctioning door switch. Refer to [DLK-197, "Removal and Installation"](#).

4.CHECK INTERMITTENT INCIDENT

Refer to [GI-41, "Intermittent Incident"](#).

>> Inspection End.

Component Inspection

INFOID:000000012242617

RF

1.CHECK DOOR SWITCH

1. Turn ignition switch OFF.
2. Disconnect malfunctioning door switch connector.
3. Check continuity between door switch terminals.

Door switch		Condition		Continuity
Terminal				
3	Ground contact is part of the switch.	Door switch	Pressed	No
			Released	Yes

Is the inspection result normal?

YES >> Inspection End.

NO >> Replace malfunctioning door switch. Refer to [DLK-197, "Removal and Installation"](#).

MOONROOF DOES NOT OPERATE PROPERLY

< SYMPTOM DIAGNOSIS >

SYMPTOM DIAGNOSIS

MOONROOF DOES NOT OPERATE PROPERLY

Diagnosis Procedure

INFOID:000000012166803

1. CHECK BCM POWER SUPPLY AND GROUND CIRCUIT

Check BCM power supply and ground circuit.
Refer to [BCS-75, "Diagnosis Procedure"](#).

Is the inspection result normal?

- YES >> GO TO 2.
- NO >> Repair or replace malfunctioning parts.

2. CHECK MOONROOF MOTOR ASSEMBLY POWER SUPPLY AND GROUND CIRCUIT

Check moonroof motor assembly power supply and ground circuit.
Refer to [RF-29, "MOONROOF MOTOR ASSEMBLY : Component Function Check"](#).

Is the inspection result normal?

- YES >> Check intermittent incident. Refer to [GI-41, "Intermittent Incident"](#).
- NO >> Repair or replace malfunctioning parts.

SUNSHADE SYSTEM DOES NOT OPERATE PROPERLY

< SYMPTOM DIAGNOSIS >

SUNSHADE SYSTEM DOES NOT OPERATE PROPERLY

Diagnosis Procedure

INFOID:000000012166804

1.CHECK BCM POWER SUPPLY AND GROUND CIRCUIT

Check BCM power supply and ground circuit.
Refer to [BCS-75. "Diagnosis Procedure"](#).

Is the inspection result normal?

- YES >> GO TO 2.
- NO >> Repair or replace the malfunctioning parts.

2.CHECK SUNSHADE MOTOR ASSEMBLY POWER SUPPLY AND GROUND CIRCUIT

Check sunshade motor assembly power supply and ground circuit.
Refer to [RF-31. "SUNSHADE MOTOR ASSEMBLY : Diagnosis Procedure"](#).

Is the inspection result normal?

- YES >> GO TO 3.
- NO >> Repair or replace the malfunctioning parts.

3.CONFIRM THE OPERATION

Confirm the operation again.

Is the result normal?

- YES >> Check intermittent incident. Refer to [GI-41. "Intermittent Incident"](#).
- NO >> GO TO 1.

A
B
C
D
E
F
G
H
I
J
L
M
N
O
P

RF

AUTO OPERATION DOES NOT OPERATE

< SYMPTOM DIAGNOSIS >

AUTO OPERATION DOES NOT OPERATE MOONROOF

MOONROOF : Diagnosis Procedure

INFOID:000000012166805

1. PERFORM INITIALIZATION PROCEDURE

Perform initialization procedure.

Refer to [RF-27, "ADDITIONAL SERVICE WHEN REPLACING CONTROL UNIT : Special Repair Requirement"](#).

Is the inspection result normal?

YES >> Moonroof system is normal.

NO >> GO TO 2.

2. CHECK MOONROOF SWITCH

Check moonroof switch.

Refer to [RF-33, "Diagnosis Procedure"](#).

Is the inspection result normal?

YES >> GO TO 3.

NO >> Repair or replace the malfunctioning parts.

3. CONFIRM THE OPERATION

Confirm the operation again.

Is the inspection result normal?

YES >> Check intermittent incident. Refer to [GI-41, "Intermittent Incident"](#).

NO >> GO TO 1.

SUNSHADE

SUNSHADE : Diagnosis Procedure

INFOID:000000012166806

1. PERFORM INITIALIZATION PROCEDURE

Refer to [RF-27, "ADDITIONAL SERVICE WHEN REPLACING CONTROL UNIT : Special Repair Requirement"](#).

Is the inspection result normal?

YES >> Sunshade system is normal.

NO >> GO TO 2.

2. CHECK SUNSHADE SWITCH

Check sunshade switch.

Refer to [RF-33, "Diagnosis Procedure"](#).

Is the inspection result normal?

YES >> GO TO 3.

NO >> Repair or replace the malfunctioning parts.

3. CONFIRM THE OPERATION

Confirm the operation again.

Is the result normal?

YES >> Check intermittent incident. Refer to [GI-41, "Intermittent Incident"](#).

NO >> GO TO 1.

ANTI-PINCH FUNCTION DOES NOT OPERATE

< SYMPTOM DIAGNOSIS >

ANTI-PINCH FUNCTION DOES NOT OPERATE MOONROOF

MOONROOF : Diagnosis Procedure

INFOID:000000012166807

1. PERFORM INITIALIZATION PROCEDURE

Perform initialization procedure.

Refer to [RF-27, "ADDITIONAL SERVICE WHEN REPLACING CONTROL UNIT : Special Repair Requirement"](#).

Is the inspection result normal?

YES >> GO TO 2.

NO >> Perform basic inspection. Refer to [RF-25, "Work Flow"](#).

2. RETEST THE ANTI-PINCH FUNCTION

Check anti-pinch operation. Refer to [RF-27, "ADDITIONAL SERVICE WHEN REPLACING CONTROL UNIT : Special Repair Requirement"](#).

Is the inspection result normal?

YES >> Inspection End.

NO >> Replace the moonroof motor assembly. Refer to [RF-52, "Removal and Installation"](#).

SUNSHADE

SUNSHADE : Diagnosis Procedure

INFOID:000000012166808

1. CHECK SUNSHADE MECHANISM

Check the following:

- Operation malfunction caused by sunshade mechanism deformation, pinched harness or other foreign materials
- Operation malfunction and interference with other parts by poor installation

Is the inspection result normal?

YES >> GO TO 2.

NO >> Repair or replace the malfunctioning parts.

2. PERFORM INITIALIZATION

Perform anti-pinch procedure.

Refer to [RF-27, "ADDITIONAL SERVICE WHEN REPLACING CONTROL UNIT : Special Repair Requirement"](#).

Is the inspection result normal?

YES >> GO TO 3.

NO >> GO TO 1.

3. RETEST THE ANTI-PINCH FUNCTION

Check anti-pinch operation. Refer to [RF-27, "ADDITIONAL SERVICE WHEN REPLACING CONTROL UNIT : Special Repair Requirement"](#).

Is the inspection result normal?

YES >> Inspection End.

NO >> Replace the sunshade motor assembly. Refer to [RF-54, "Removal and Installation"](#).

A
B
C
D
E
F
G
H
I
J
RF
L
M
N
O
P

RETAINED POWER OPERATION DOES NOT OPERATE PROPERLY

< SYMPTOM DIAGNOSIS >

RETAINED POWER OPERATION DOES NOT OPERATE PROPERLY

Diagnosis Procedure

INFOID:000000012166809

1.CHECK FRONT DOOR SWITCH

Check (LH and RH) front door switches.
Refer to [DLK-95. "Diagnosis Procedure"](#).

Is the inspection result normal?

YES >> GO TO 2.

NO >> Repair or replace the malfunctioning parts.

2.CONFIRM THE OPERATION

Confirm the operation again.

Is the inspection result normal?

YES >> Check intermittent incident. Refer to [GI-41. "Intermittent Incident"](#).

NO >> GO TO 1.

SQUEAK AND RATTLE TROUBLE DIAGNOSES

< SYMPTOM DIAGNOSIS >

SQUEAK AND RATTLE TROUBLE DIAGNOSES

Work Flow

INFOID:000000012166810

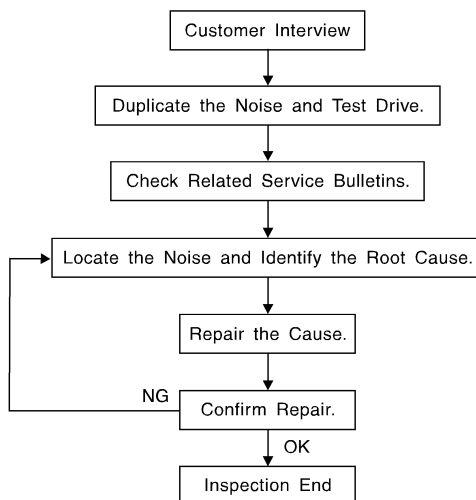

SBT842

CUSTOMER INTERVIEW

Interview the customer if possible, to determine the conditions that exist when the noise occurs. Use the Diagnostic Worksheet during the interview to document the facts and conditions when the noise occurs and any customer's comments; refer to [RF-47, "Diagnostic Worksheet"](#). This information is necessary to duplicate the conditions that exist when the noise occurs.

- The customer may not be able to provide a detailed description or the location of the noise. Attempt to obtain all the facts and conditions that exist when the noise occurs (or does not occur).
- If there is more than one noise in the vehicle, be sure to diagnose and repair the noise that the customer is concerned about. This can be accomplished by test driving the vehicle with the customer.
- After identifying the type of noise, isolate the noise in terms of its characteristics. The noise characteristics are provided so the customer, service adviser and technician are all speaking the same language when defining the noise.
- Squeak —(Like tennis shoes on a clean floor)
Squeak characteristics include the light contact/fast movement/brought on by road conditions/hard surfaces = higher pitch noise/softer surfaces = lower pitch noises/edge to surface = chirping.
- Creak—(Like walking on an old wooden floor)
Creak characteristics include firm contact/slow movement/twisting with a rotational movement/pitch dependent on materials/often brought on by activity.
- Rattle—(Like shaking a baby rattle)
Rattle characteristics include the fast repeated contact/vibration or similar movement/loose parts/missing clip or fastener/incorrect clearance.
- Knock —(Like a knock on a door)
Knock characteristics include hollow sounding/sometimes repeating/often brought on by driver action.
- Tick—(Like a clock second hand)
Tick characteristics include gentle contacting of light materials/loose components/can be caused by driver action or road conditions.
- Thump—(Heavy, muffled knock noise)
Thump characteristics include softer knock/dead sound often brought on by activity.
- Buzz—(Like a bumble bee)
Buzz characteristics include high frequency rattle/firm contact.
- Often the degree of acceptable noise level will vary depending upon the person. A noise that you may judge as acceptable may be very irritating to the customer.
- Weather conditions, especially humidity and temperature, may have a great effect on noise level.

DUPLICATE THE NOISE AND TEST DRIVE

If possible, drive the vehicle with the customer until the noise is duplicated. Note any additional information on the Diagnostic Worksheet regarding the conditions or location of the noise. This information can be used to duplicate the same conditions when you confirm the repair.

SQUEAK AND RATTLE TROUBLE DIAGNOSES

< SYMPTOM DIAGNOSIS >

If the noise can be duplicated easily during the test drive, to help identify the source of the noise, try to duplicate the noise with the vehicle stopped by doing one or all of the following:

- 1) Close a door.
 - 2) Tap or push/pull around the area where the noise appears to be coming from.
 - 3) Rev the engine.
 - 4) Use a floor jack to recreate vehicle "twist".
 - 5) At idle, apply engine load (electrical load, half-clutch on M/T model, drive position on CVT and A/T models).
 - 6) Raise the vehicle on a hoist and hit a tire with a rubber hammer.
- Drive the vehicle and attempt to duplicate the conditions the customer states exist when the noise occurs.
 - If it is difficult to duplicate the noise, drive the vehicle slowly on an undulating or rough road to stress the vehicle body.

CHECK RELATED SERVICE BULLETINS

After verifying the customer concern or symptom, check ASIST for Technical Service Bulletins (TSBs) related to that concern or symptom.

If a TSB relates to the symptom, follow the procedure to repair the noise.

LOCATE THE NOISE AND IDENTIFY THE ROOT CAUSE

1. Narrow down the noise to a general area. To help pinpoint the source of the noise, use a listening tool (Chassis Ear: J-39570, Engine Ear: J-39565 and mechanic's stethoscope).
2. Narrow down the noise to a more specific area and identify the cause of the noise by:
 - removing the components in the area that you suspect the noise is coming from.
Do not use too much force when removing clips and fasteners, otherwise clips and fasteners can be broken or lost during the repair, resulting in the creation of new noise.
 - tapping or pushing/pulling the component that you suspect is causing the noise.
Do not tap or push/pull the component with excessive force, otherwise the noise will be eliminated only temporarily.
 - feeling for a vibration with your hand by touching the component(s) that you suspect is (are) causing the noise.
 - placing a piece of paper between components that you suspect are causing the noise.
 - looking for loose components and contact marks.Refer to [RF-44. "Generic Squeak and Rattle Troubleshooting"](#).

REPAIR THE CAUSE

- If the cause is a loose component, tighten the component securely.
- If the cause is insufficient clearance between components:
 - separate components by repositioning or loosening and retightening the component, if possible.
 - insulate components with a suitable insulator such as urethane pads, foam blocks, felt cloth tape or urethane tape. A NISSAN Squeak and Rattle Kit (J-50397) is available through your authorized NISSAN Parts Department.

CAUTION:

Do not use excessive force as many components are constructed of plastic and may be damaged.

NOTE:

- Always check with the Parts Department for the latest parts information.
- The materials contained in the NISSAN Squeak and Rattle Kit (J-50397) are listed on the inside cover of the kit; and can each be ordered separately as needed.
- The following materials not found in the kit can also be used to repair squeaks and rattles.
 - SILICONE GREASE: Use instead of UHMW tape that will be visible or does not fit. The silicone grease will only last a few months.
 - SILICONE SPRAY: Use when grease cannot be applied.
 - DUCT TAPE: Use to eliminate movement.

CONFIRM THE REPAIR

Confirm that the cause of a noise is repaired by test driving the vehicle. Operate the vehicle under the same conditions as when the noise originally occurred. Refer to the notes on the Diagnostic Worksheet.

Generic Squeak and Rattle Troubleshooting

INFOID:000000012166811

Refer to Table of Contents for specific component removal and installation information.

INSTRUMENT PANEL

Most incidents are caused by contact and movement between:

SQUEAK AND RATTLE TROUBLE DIAGNOSES

< SYMPTOM DIAGNOSIS >

1. Cluster lid A and the instrument panel
2. Acrylic lens and combination meter housing
3. Instrument panel to front pillar finisher
4. Instrument panel to windshield
5. Instrument panel pins
6. Wiring harnesses behind the combination meter
7. A/C defroster duct and duct joint

These incidents can usually be located by tapping or moving the components to duplicate the noise or by pressing on the components while driving to stop the noise. Most of these incidents can be repaired by applying felt cloth tape or silicone spray (in hard to reach areas). Urethane pads can be used to insulate wiring harness.

CAUTION:

Do not use silicone spray to isolate a squeak or rattle. If you saturate the area with silicone, you will not be able to recheck the repair.

CENTER CONSOLE

Components to pay attention to include:

1. Shift selector assembly cover to finisher
2. A/C control unit and cluster lid C
3. Wiring harnesses behind audio and A/C control unit

The instrument panel repair and isolation procedures also apply to the center console.

DOORS

Pay attention to the:

1. Finisher and inner panel making a slapping noise
2. Inside handle escutcheon to door finisher
3. Wiring harnesses tapping
4. Door striker out of alignment causing a popping noise on starts and stops

Tapping or moving the components or pressing on them while driving to duplicate the conditions can isolate many of these incidents. You can usually insulate the areas with felt cloth tape or insulator foam blocks from the NISSAN Squeak and Rattle Kit (J-50397) to repair the noise.

TRUNK

Trunk noises are often caused by a loose jack or loose items put into the trunk by the owner.

In addition look for:

1. Trunk lid bumpers out of adjustment
2. Trunk lid striker out of adjustment
3. The trunk lid torsion bars knocking together
4. A loose license plate or bracket

Most of these incidents can be repaired by adjusting, securing or insulating the item(s) or component(s) causing the noise.

SUNROOF/HEADLINING

Noises in the sunroof/headlining area can often be traced to one of the following:

1. Sunroof lid, rail, linkage or seals making a rattle or light knocking noise
2. Sun visor shaft shaking in the holder
3. Front or rear windshield touching headliner and squeaking

Again, pressing on the components to stop the noise while duplicating the conditions can isolate most of these incidents. Repairs usually consist of insulating with felt cloth tape.

OVERHEAD CONSOLE (FRONT AND REAR)

Overhead console noises are often caused by the console panel clips not being engaged correctly. Most of these incidents are repaired by pushing up on the console at the clip locations until the clips engage.

In addition look for:

1. Loose harness or harness connectors.
2. Front console map/reading lamp lens loose.

A
B
C
D
E
F
G
H
I
J
RF
L
M
N
O
P

SQUEAK AND RATTLE TROUBLE DIAGNOSES

< SYMPTOM DIAGNOSIS >

3. Loose screws at console attachment points.

SEATS

When isolating seat noise it's important to note the position the seat is in and the load placed on the seat when the noise is present. These conditions should be duplicated when verifying and isolating the cause of the noise.

Cause of seat noise include:

1. Headrest rods and holder
2. A squeak between the seat pad cushion and frame
3. The rear seatback lock and bracket

These noises can be isolated by moving or pressing on the suspected components while duplicating the conditions under which the noise occurs. Most of these incidents can be repaired by repositioning the component or applying urethane tape to the contact area.

UNDERHOOD

Some interior noise may be caused by components under the hood or on the engine wall. The noise is then transmitted into the passenger compartment.

Causes of transmitted underhood noise include:

1. Any component installed to the engine wall
2. Components that pass through the engine wall
3. Engine wall mounts and connectors
4. Loose radiator installation pins
5. Hood bumpers out of adjustment
6. Hood striker out of adjustment

These noises can be difficult to isolate since they cannot be reached from the interior of the vehicle. The best method is to secure, move or insulate one component at a time and test drive the vehicle. Also, engine rpm or load can be changed to isolate the noise. Repairs can usually be made by moving, adjusting, securing, or insulating the component causing the noise.

SQUEAK AND RATTLE TROUBLE DIAGNOSES

< SYMPTOM DIAGNOSIS >

Diagnostic Worksheet

INFOID:000000012166812

Dear Customer:

We are concerned about your satisfaction with your vehicle. Repairing a squeak or rattle sometimes can be very difficult. To help us fix your vehicle right the first time, please take a moment to note the area of the vehicle where the squeak or rattle occurs and under what conditions. You may be asked to take a test drive with a service advisor or technician to ensure we confirm the noise you are hearing.

SQUEAK & RATTLE DIAGNOSTIC WORKSHEET

I. WHERE DOES THE NOISE COME FROM? (circle the area of the vehicle)

The illustrations are for reference only, and may not reflect the actual configuration of your vehicle.

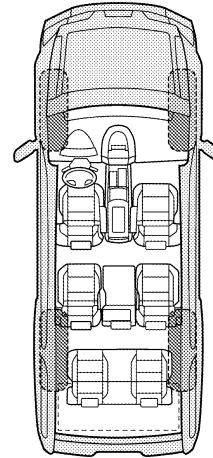
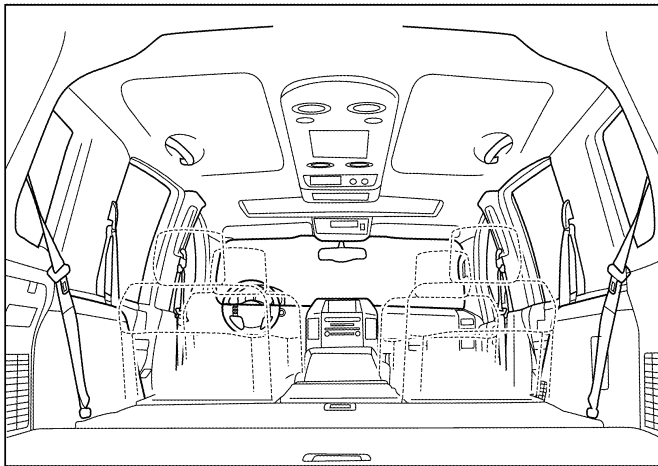
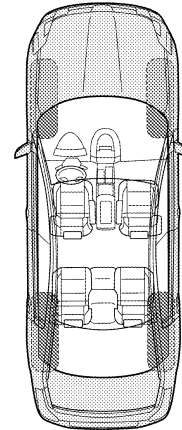
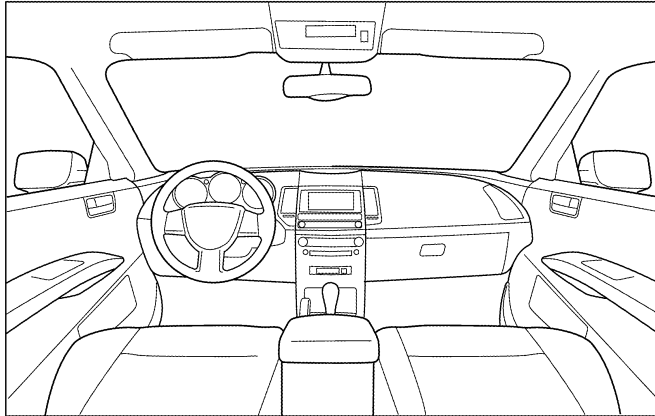

Continue to page 2 of the worksheet and briefly describe the location of the noise or rattle. In addition, please indicate the conditions which are present when the noise occurs.

A
B
C
D
E
F
G
H
I
J
RF
L
M
N
O
P

SQUEAK AND RATTLE TROUBLE DIAGNOSES

< SYMPTOM DIAGNOSIS >

SQUEAK & RATTLE DIAGNOSTIC WORKSHEET - page 2

Briefly describe the location where the noise occurs:

II. WHEN DOES IT OCCUR? (please check the boxes that apply)

- | | |
|---|--|
| <input type="checkbox"/> Anytime | <input type="checkbox"/> After sitting out in the rain |
| <input type="checkbox"/> 1st time in the morning | <input type="checkbox"/> When it is raining or wet |
| <input type="checkbox"/> Only when it is cold outside | <input type="checkbox"/> Dry or dusty conditions |
| <input type="checkbox"/> Only when it is hot outside | <input type="checkbox"/> Other: |

III. WHEN DRIVING:

- Through driveways
- Over rough roads
- Over speed bumps
- Only about ____ mph
- On acceleration
- Coming to a stop
- On turns: left, right or either (circle)
- With passengers or cargo
- Other: _____
- After driving ____ miles or ____ minutes

IV. WHAT TYPE OF NOISE

- Squeak (like tennis shoes on a clean floor)
- Creak (like walking on an old wooden floor)
- Rattle (like shaking a baby rattle)
- Knock (like a knock at the door)
- Tick (like a clock second hand)
- Thump (heavy muffled knock noise)
- Buzz (like a bumble bee)

TO BE COMPLETED BY DEALERSHIP PERSONNEL

Test Drive Notes:

	YES	NO	Initials of person performing
Vehicle test driven with customer	<input type="checkbox"/>	<input type="checkbox"/>	_____
- Noise verified on test drive	<input type="checkbox"/>	<input type="checkbox"/>	_____
- Noise source located and repaired	<input type="checkbox"/>	<input type="checkbox"/>	_____
- Follow up test drive performed to confirm repair	<input type="checkbox"/>	<input type="checkbox"/>	_____

VIN: _____ Customer Name _____
W.O.# _____ Date: _____

This form must be attached to Work Order

LAI0071E

GLASS LID

< REMOVAL AND INSTALLATION >

REMOVAL AND INSTALLATION

GLASS LID

Exploded View

INFOID:0000000012371173

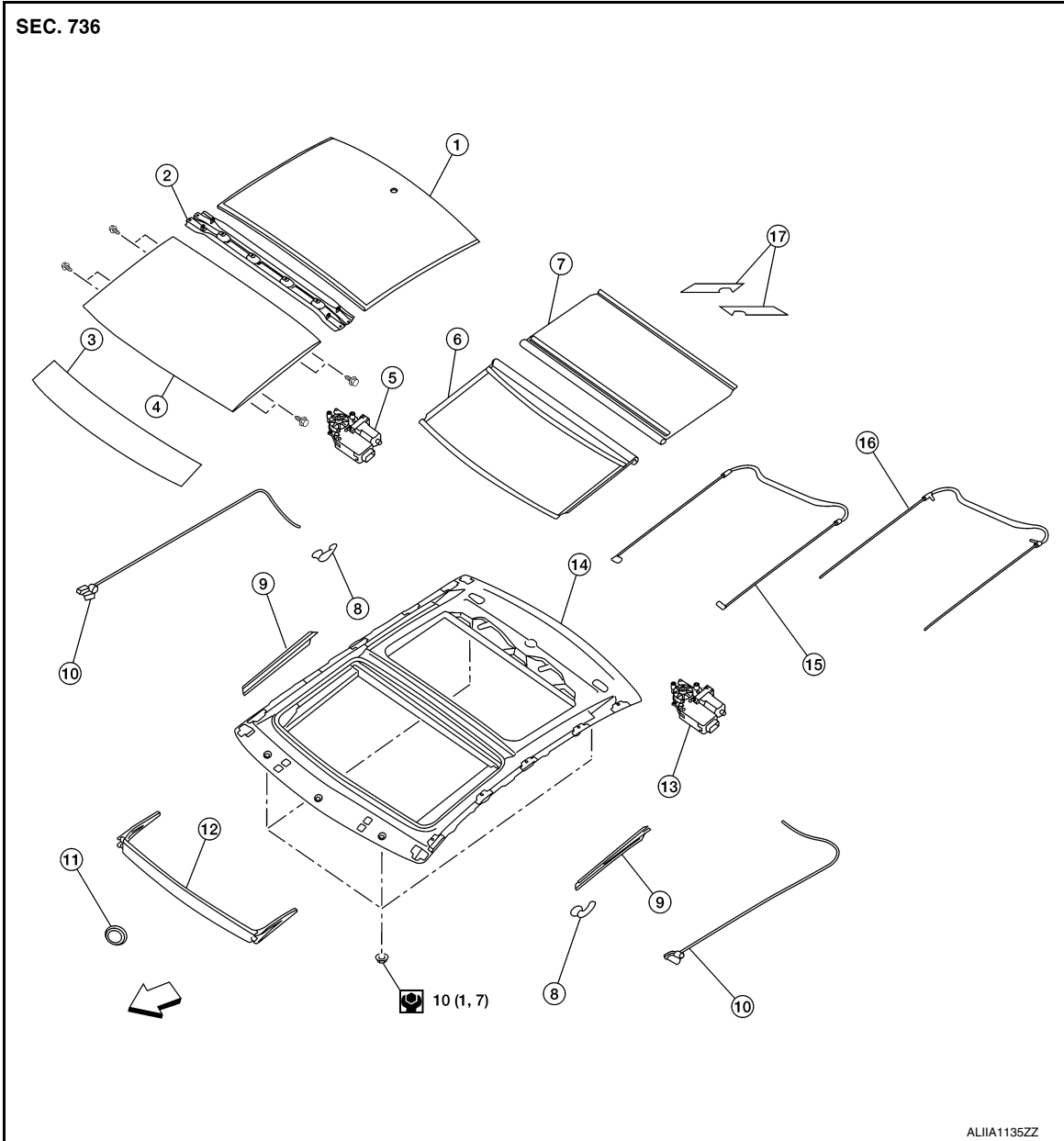

- | | | |
|-------------------------------------|------------------------------|-----------------------------------|
| 1. Rear moonroof glass | 2. Sunshade carrier assembly | 3. Front moonroof glass |
| 4. Glass lid | 5. Moonroof motor assembly | 6. Front sunshade |
| 7. Rear sunshade | 8. Link and guide (LH/RH) | 9. Inner blind (LH/RH) |
| 10. Moonroof guide assembly (LH/RH) | 11. Plug | 12. Wind deflector |
| 13. Sunshade motor assembly | 14. Moonroof unit assembly | 15. Front sunshade guide assembly |
| 16. Rear sunshade guide assembly | 17. Bolt cover (LH/RH) | ⇐ Front |

GLASS LID

< REMOVAL AND INSTALLATION >

Removal and Installation

INFOID:000000012303622

REMOVAL

CAUTION:

- Always work with a helper.
- Handle glass lid with care to prevent damage.

NOTE:

For easier and more accurate installation, always mark each point before removal.

1. Open sunshade.
2. Tilt glass lid up, then slide rearward to expose all the glass lid bolts.
3. Release the slide clip, then remove inner blind (LH/RH) (1) from the glass lid (2).

⇐ : Front

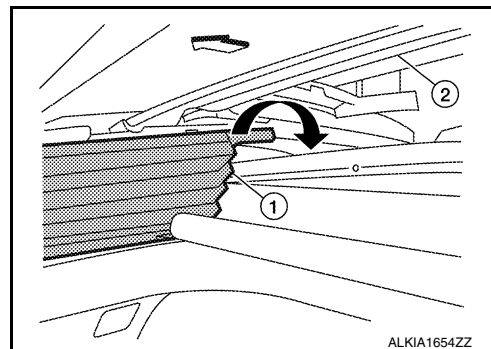

4. Release pawl and remove bolt cover (LH/RH) (1) from glass lid (2).

⇐ : Front

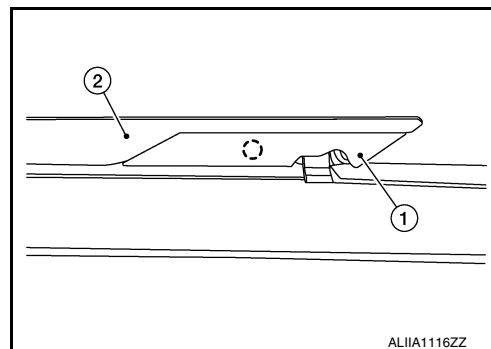

5. Remove the glass lid rear bolts (LH/RH) (A).

⇐ : Front

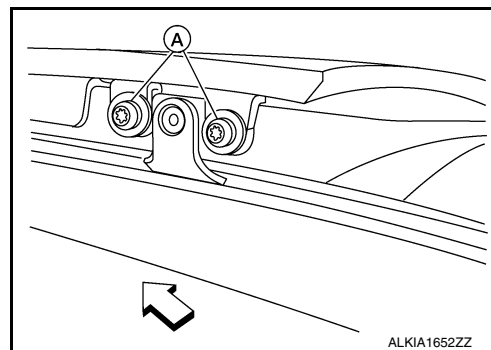

6. Remove the glass lid front bolts (LH/RH) (B).

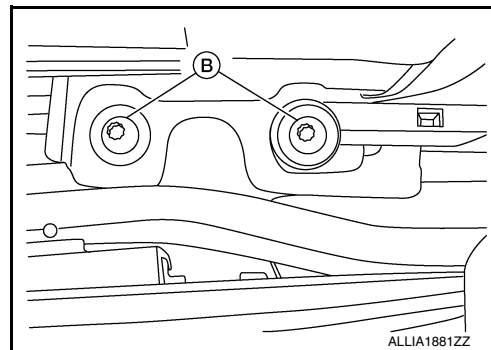

7. Remove the glass lid from the vehicle.

GLASS LID

< REMOVAL AND INSTALLATION >

INSTALLATION

CAUTION:

After installing the glass lid, perform the water leak test.

Installation is in the reverse order of removal.

NOTE:

- After installing, perform glass lid adjustment procedure. Refer to [RF-57. "Inspection and Adjustment"](#).
- After adjustment, always check for proper moonroof operation. If necessary, perform initialization procedure to synchronize entire system. Refer to [RF-27. "ADDITIONAL SERVICE WHEN REPLACING CONTROL UNIT : Special Repair Requirement"](#).

A

B

C

D

E

F

G

H

I

J

RF

L

M

N

O

P

MOONROOF MOTOR ASSEMBLY

< REMOVAL AND INSTALLATION >

MOONROOF MOTOR ASSEMBLY

Exploded View

INFOID:000000012371174

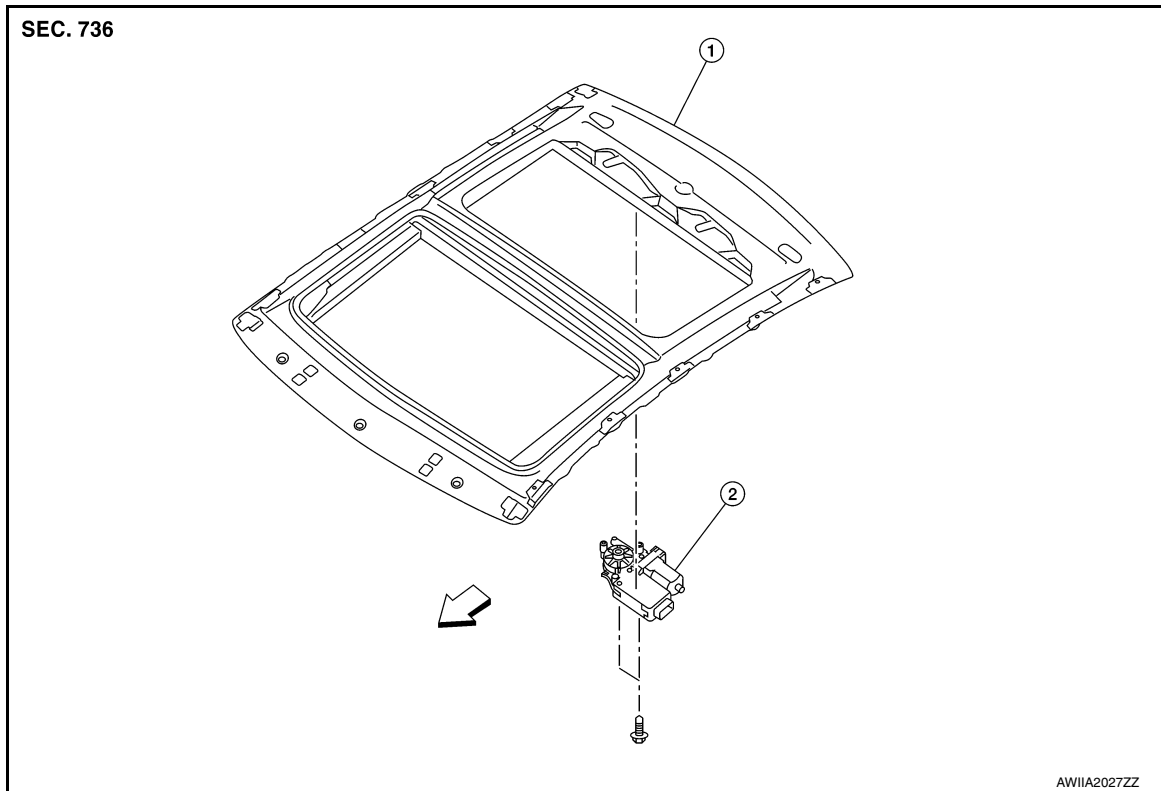

1. Moonroof unit assembly

2. Moonroof motor assembly

← Front

Removal and Installation

INFOID:000000012303623

REMOVAL

CAUTION:

- Before removing moonroof motor, check that glass lid is fully closed.
- After removing moonroof motor, do not attempt to rotate moonroof motor assembly as a single unit.

1. Close glass lid.
2. Remove the headlining. Refer to [INT-48, "Removal and Installation"](#).
3. Disconnect the harness connector (A) from the moonroof motor assembly (1).
4. Remove moonroof motor assembly screws (B), then remove moonroof motor assembly from moonroof unit assembly.

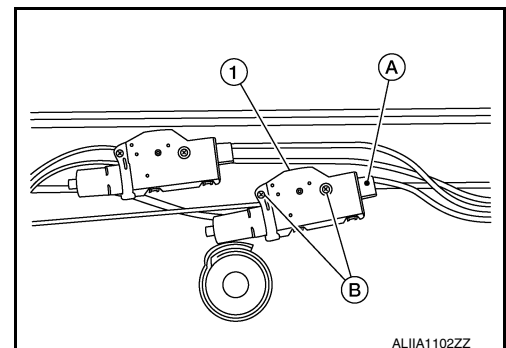

INSTALLATION

CAUTION:

Before installing the moonroof motor assembly, be sure to place the link and wire assembly in the symmetrical and fully closed position.

MOONROOF MOTOR ASSEMBLY

< REMOVAL AND INSTALLATION >

1. Move the moonroof motor assembly laterally so that the gear is completely engaged into the wire on the moonroof unit assembly frame, and mounting surface becomes parallel.
2. Install and tighten moonroof motor assembly screws.
3. Connect the harness connector to the moonroof motor assembly.
4. Install the headlining. Refer to [JNT-48, "Removal and Installation"](#).
5. Perform initialization procedure. Refer to [RF-27, "ADDITIONAL SERVICE WHEN REPLACING CONTROL UNIT : Special Repair Requirement"](#).

A

B

C

D

E

F

G

H

I

J

RF

L

M

N

O

P

SUNSHADE MOTOR ASSEMBLY

< REMOVAL AND INSTALLATION >

SUNSHADE MOTOR ASSEMBLY

Exploded View

INFOID:000000012371175

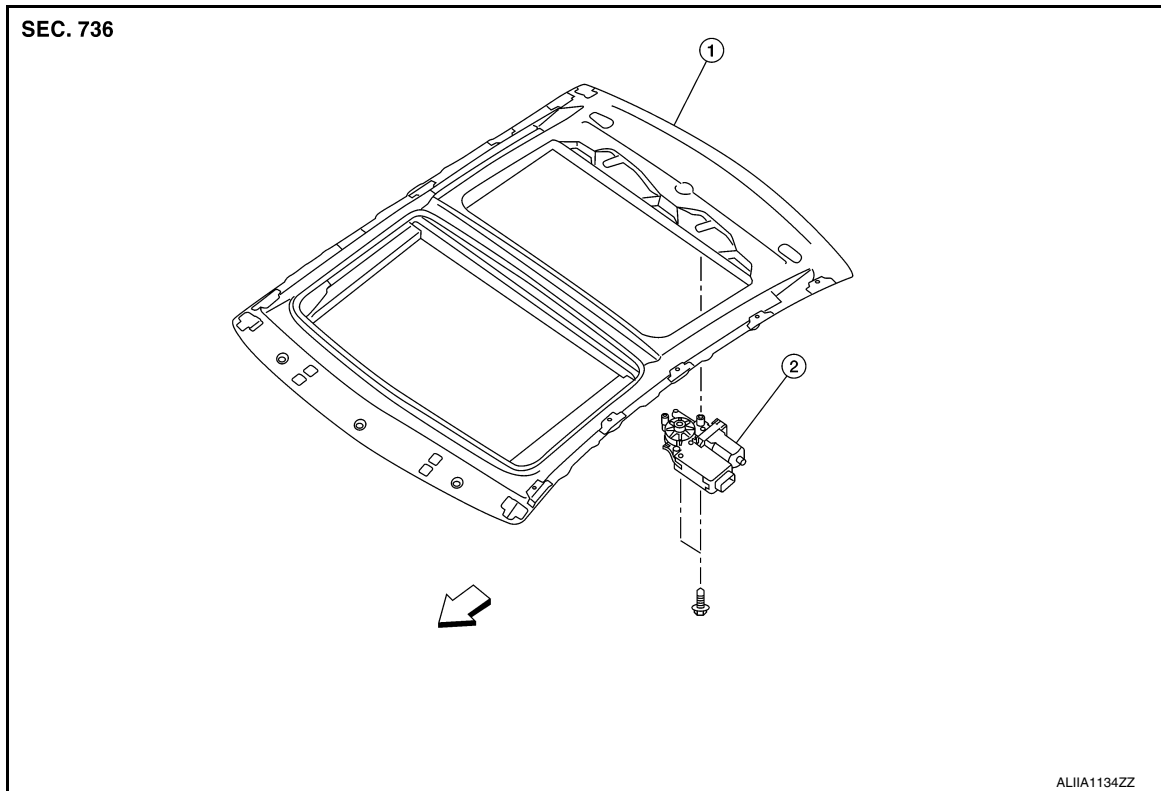

1. Moonroof unit assembly

2. Sunshade motor assembly

← Front

Removal and Installation

INFOID:000000012303624

REMOVAL

CAUTION:

- Before removing sunshade motor, check that glass lid is fully closed.
- After removing sunshade motor, do not attempt to rotate sunshade motor assembly as a single unit.

1. Close glass lid.
2. Remove the headlining. Refer to [INT-48, "Removal and Installation"](#).
3. Disconnect the harness connector (A) from the sunshade motor assembly (1).
4. Remove sunshade motor assembly screws (B), then remove sunshade motor assembly from moonroof unit assembly.

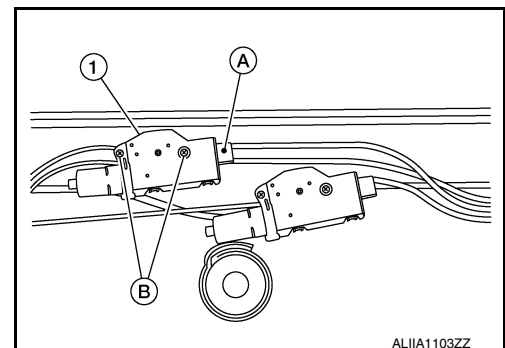

INSTALLATION

CAUTION:

Before installing the sunshade motor assembly, be sure to place the link and wire assembly in the symmetrical and fully closed position.

SUNSHADE MOTOR ASSEMBLY

< REMOVAL AND INSTALLATION >

1. Move the sunshade motor assembly laterally so that the gear is completely engaged into the wire on the moonroof unit assembly frame, and mounting surface becomes parallel.
2. Install and tighten sunshade motor assembly screws.
3. Connect the harness connector to the sunshade motor assembly.
4. Install the headlining. Refer to [JNT-48, "Removal and Installation"](#).
5. Perform initialization procedure. Refer to [RF-27, "ADDITIONAL SERVICE WHEN REPLACING CONTROL UNIT : Special Repair Requirement"](#).

A

B

C

D

E

F

G

H

I

J

RF

L

M

N

O

P

ROOF LINK ASSEMBLY

< REMOVAL AND INSTALLATION >

ROOF LINK ASSEMBLY

Exploded View

INFOID:000000012371176

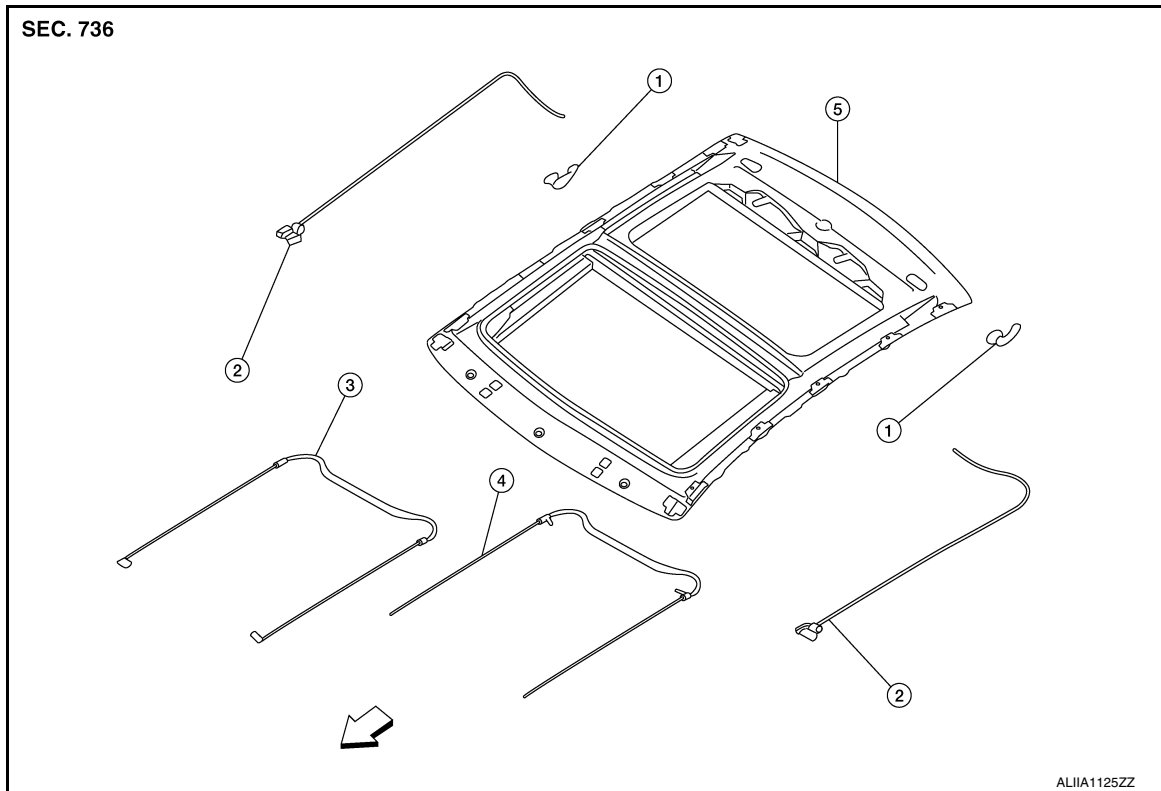

- | | | |
|---------------------------------|------------------------------------|----------------------------------|
| 1. Link and guide (LH/RH) | 2. Moonroof guide assembly (LH/RH) | 3. Front sunshade guide assembly |
| 4. Rear sunshade guide assembly | 5. Moonroof unit assembly | ⇐ Front |

Removal and Installation

INFOID:000000012303625

Removal

1. Remove the sunshade. Refer to [RF-54, "Removal and Installation"](#).
2. Remove the wind deflector. Refer to [RF-70, "Removal and Installation"](#).
3. Remove the glass lid assembly. Refer to [RF-50, "Removal and Installation"](#).
4. Remove the moonroof motor. Refer to [RF-52, "Removal and Installation"](#).
5. Remove the sunshade motor. Refer to [RF-54, "Removal and Installation"](#).
6. Remove the track assembly.
 - Remove the 5 screws and 4 harness clips (LH).
 - Remove the 5 screws (RH).
7. Slide the sunshade guide assembly (LH/RH) out of the channels.
8. Slide the moonroof guide assembly (LH/RH) out of the channels.
9. Slide the link and guide (LH/RH) out of the channels.

Installation

Installation is in the reverse order of removal.

MOONROOF UNIT ASSEMBLY

< REMOVAL AND INSTALLATION >

MOONROOF UNIT ASSEMBLY

Inspection and Adjustment

INFOID:000000012303626

INSPECTION

Wind Deflector

1. Open glass lid assembly fully.
2. Visually check for proper installation, damaged/deteriorated components, or foreign objects within mechanism. Correct as required for smooth operation.
3. Check for grease at the wind deflector arm (1) and pivot areas. If necessary, apply a sufficient amount of grease for non-binding operation.

↔ : Front

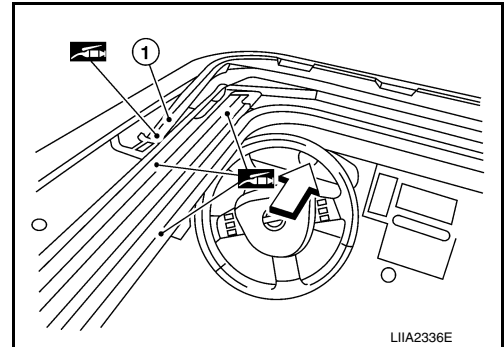

4. Check that the wind deflector (1) moves freely within the moonroof unit assembly while manually pressing down and releasing. If a malfunction is detected, remove the moonroof unit assembly and visually inspect; refer to [RF-59, "Removal and Installation"](#). If damage is found, replace either wind deflector (1) or moonroof unit assembly as required.

↔ : Front

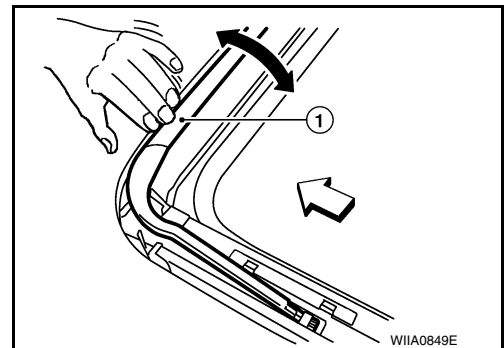

Link And Wire Assembly

NOTE:

Before replacing a suspect part, make sure it is the source of noise being experienced.

1. Check link to determine if coating film has peeled off excessively enough that substrate is visible. Check also to determine if link is the source of noise. Replace as necessary.
2. Visually check to determine if a sufficient amount of grease has been applied to wire or rail groove. If not, add grease as required.
3. Check wire for any damage or deterioration.

ADJUSTMENT

CAUTION:

- Always work with a helper.
- Handle glass lid assembly with care to prevent damage.

NOTE:

- For easier and more accurate installation, always mark each point before removal.
- After any adjustment, check moonroof operation and glass lid assembly alignment.

A
B
C
D
E
F
G
H
I
J
RF
L
M
N
O
P

MOONROOF UNIT ASSEMBLY

< REMOVAL AND INSTALLATION >

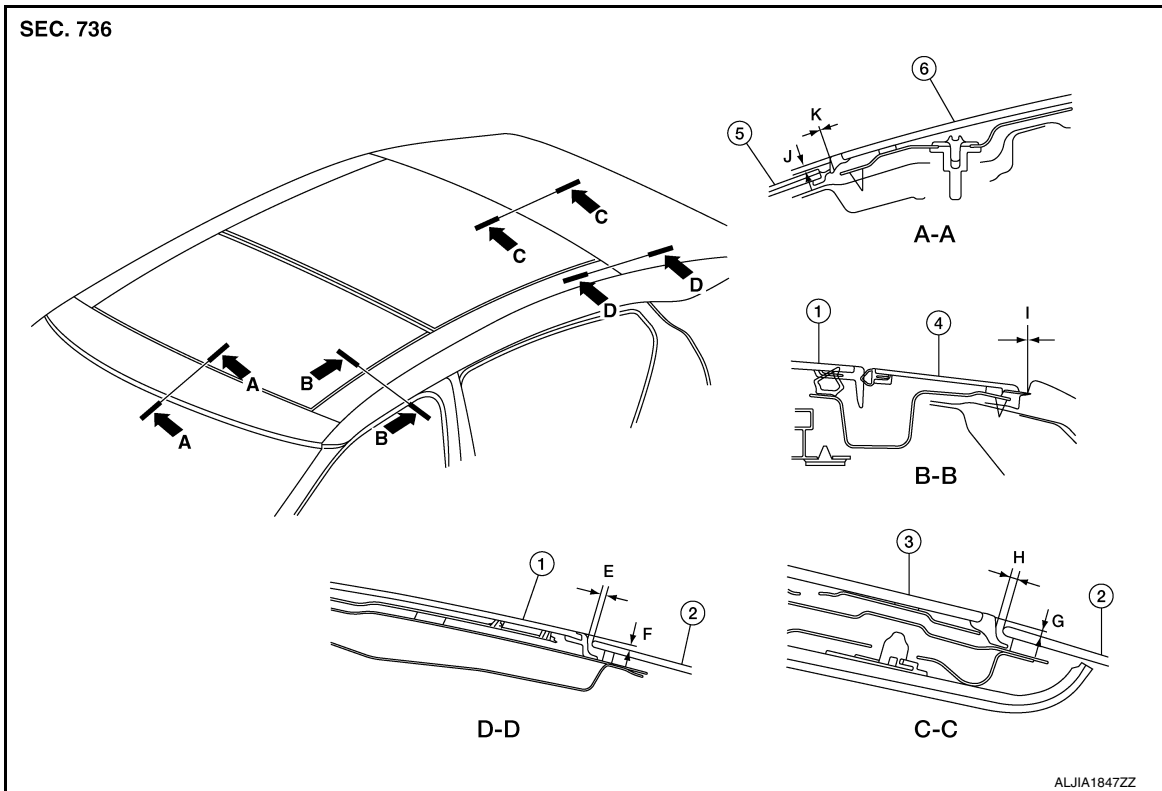

Unit: mm (in)

- | | | |
|--------------------------------------|--------------------------------------|--|
| 1. Glass lid | 2. Rear window glass | 3. Rear moonroof glass |
| 4. Roof side finisher | 5. Windshield | 6. Front moonroof glass |
| E. 3.0 ± 2.2 (0.118 \pm 0.087) | F. 2.7 ± 2.0 (0.106 \pm 0.079) | G. $2.0 + 2.2 - 1.7$ (0.079 + 0.087 - 0.067) |
| H. 3.0 ± 2.1 (0.118 \pm 0.083) | I. 0.0 (No clearance) | J. 4.5 ± 2.0 (0.177 \pm 0.079) |
| K. 0.0 (No clearance) | | |

1. Open sunshade.
2. Tilt glass lid up, then slide rearward to expose all the glass lid bolts.
3. Loosen glass lid bolts (4 each on left and right sides), then fully close glass lid.
4. Manually adjust glass lid from outside of vehicle so gaps A-A and B-B are within specifications.

NOTE:

Temporarily snug glass lid bolts to prevent movement between each adjustment.

5. Tilt glass lid up and down several times using moonroof switch to check that it operates smoothly.
6. Open glass lid up and tighten bolts. Refer to [RF-49, "Exploded View"](#).
7. Perform initialization procedure to make sure the closing operation is accurate and synchronized properly. Refer to [RF-27, "ADDITIONAL SERVICE WHEN REPLACING CONTROL UNIT : Special Repair Requirement"](#).
8. Perform water leak test.

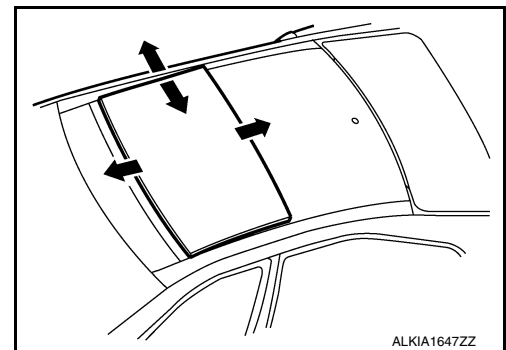

MOONROOF UNIT ASSEMBLY

< REMOVAL AND INSTALLATION >

Exploded View

INFOID:000000012303627

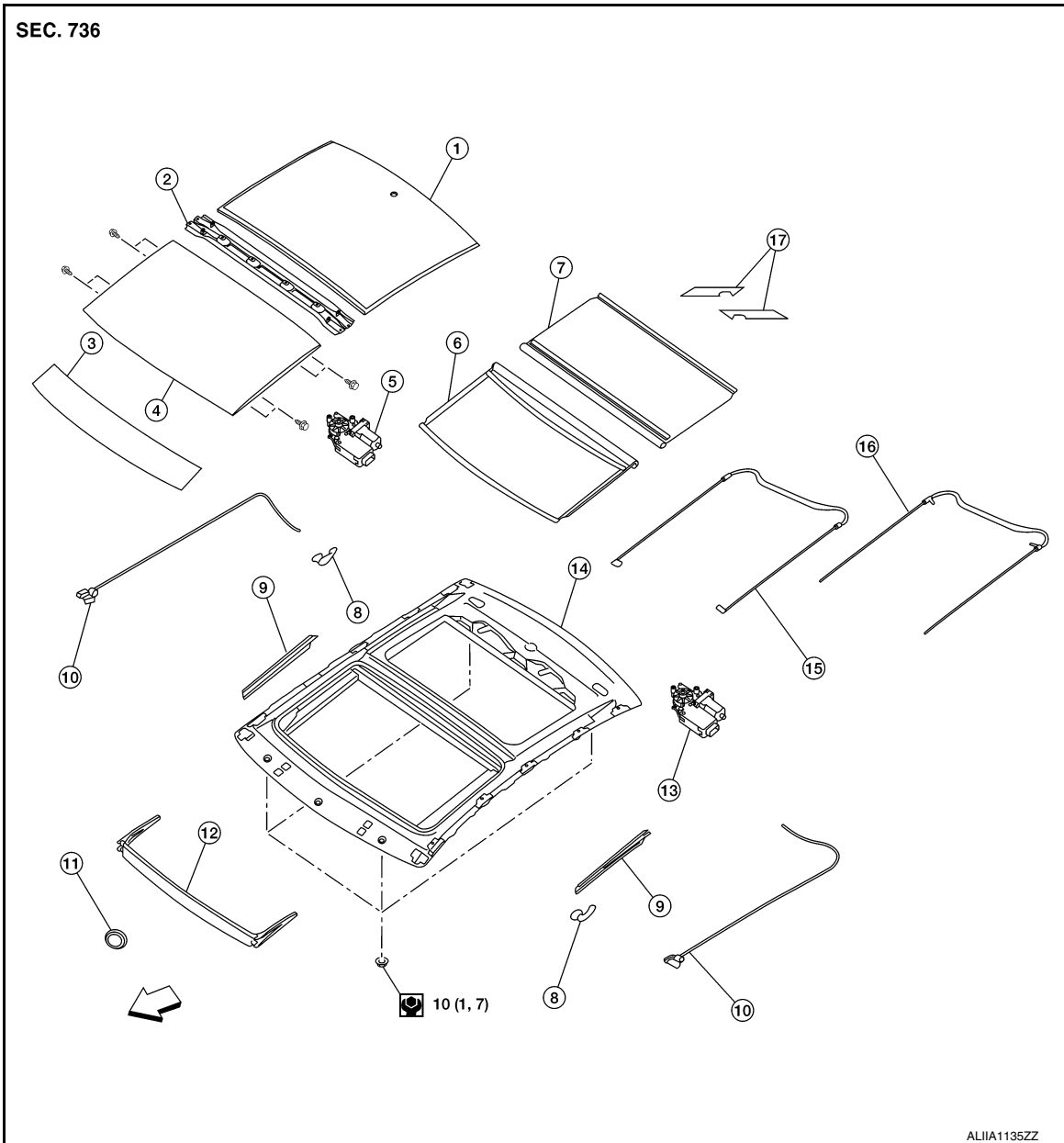

- | | | |
|-------------------------------------|------------------------------|-----------------------------------|
| 1. Rear moonroof glass | 2. Sunshade carrier assembly | 3. Front moonroof glass |
| 4. Glass lid | 5. Moonroof motor assembly | 6. Front sunshade |
| 7. Rear sunshade | 8. Link and guide (LH/RH) | 9. Inner blind (LH/RH) |
| 10. Moonroof guide assembly (LH/RH) | 11. Plug | 12. Wind deflector |
| 13. Sunshade motor assembly | 14. Moonroof unit assembly | 15. Front sunshade guide assembly |
| 16. Rear sunshade guide assembly | 17. Bolt cover (LH/RH) | ← Front |

Removal and Installation

INFOID:000000012303628

REMOVAL

CAUTION:

- Before servicing, turn ignition switch OFF, disconnect both battery terminals and wait at least 3 minutes.

MOONROOF UNIT ASSEMBLY

< REMOVAL AND INSTALLATION >

- **Always work with a helper.**
 - **When taking moonroof unit assembly out, use cloths to protect the seats and trim from damage.**
1. Disconnect the negative and positive battery terminals, then wait at least 3 minutes. Refer to [PG-101, "Removal and Installation \(Battery\)"](#).
 2. Remove the headlining. Refer to [INT-48, "Removal and Installation"](#).
 3. Remove the glass lid. Refer to [RF-50, "Removal and Installation"](#).
 4. Remove the wind deflector. Refer to [RF-70, "Removal and Installation"](#).
 5. Apply protective tape over the weather stripping seal.
 6. Remove the sunshade carrier assembly. Refer to [RF-72, "Removal and Installation"](#).
 7. Apply protective tape to the body surrounding the entire moonroof unit assembly.
 8. Remove the front moonroof glass. Refer to [RF-64, "Removal and Installation"](#).
 9. Remove the roof finishers (LH/RH). Refer to [EXT-36, "Removal and Installation"](#).
 10. Remove the rear window glass. Refer to [GW-27, "Removal and Installation"](#).
 11. Remove the antenna. Refer to [AV-196, "Removal and Installation"](#).
 12. Remove the rear moonroof glass. Refer to [RF-67, "Removal and Installation"](#).
 13. Disconnect the harness connectors from the moonroof motor assembly and sunshade motor assembly.
 14. Remove bolts from moonroof bracket (LH/RH) and remove.
 15. Remove nuts from the moonroof unit assembly.
 16. Cut adhesive.
 - Pass piano wire through the adhesive with a wire pierce.
 - Tie piano wire on both ends to assist in wire grip.
 - Pull piano wire with sawing motion to cut through adhesive, working around entire circumference.
 17. Using a helper, carefully lift each side and remove moonroof unit assembly from vehicle.
 18. If necessary remove moonroof plug.

INSTALLATION

WARNING:

- **Keep heat and open flames away as primers and adhesive are flammable.**
- **The materials contained in the kit are harmful if swallowed, and may irritate skin and eyes. Do not let them contact the skin or eyes.**
- **Use in an open, well ventilated location. Do not breathe the vapors. They may be harmful if inhaled. Move immediately to an area with fresh air if affected by vapor inhalation.**

CAUTION:

After installing the moonroof unit assembly and glass lid, perform the leak test and check that there is no air or water intrusion.

NOTE:

- Use a genuine Nissan Urethane Adhesive Kit (if available) or an equivalent and follow the instructions furnished with it.
 - Inform the customer that the vehicle should remain stationary until the urethane adhesive has completely cured (approximately 24 hours). Curing time varies with temperature and humidity.
1. Using a suitable tool, trim the adhesive (sealant) remaining on body down to approximately 2 mm thick (a) so that the contour becomes smooth.

CAUTION:

If bonded area on body is scratched, be sure to repair it with a 2-component urethane. Do not use lacquer.

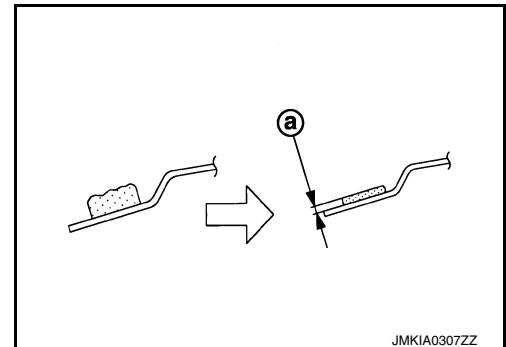

2. When installing new moonroof unit assembly, mount the roof frame dry (no adhesive) first onto the vehicle and paint mating marks on body and moonroof frame, then remove moonroof frame again.
3. Thoroughly clean bonding area on moonroof frame and body with isopropyl alcohol or equivalent.

MOONROOF UNIT ASSEMBLY

< REMOVAL AND INSTALLATION >

4. Apply primer to the body and the moonroof frame (lower) surfaces.
5. Apply adhesive along the entire circumference of the moonroof unit assembly frame contact area of body within the time specified in the instructions for the adhesive.
 - Open adhesive by cutting off the nozzle tip and set it in a sealant gun.
 - Form a continuous bead of adhesive resembling the measurements in applied thickness (A), and in applied width (B) on the body panel.

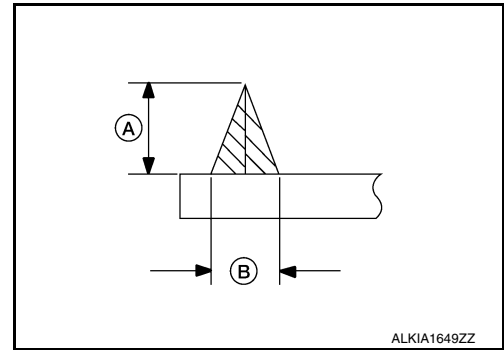

Adhesive applied thickness (A) : 13 ± 1 mm (0.51 in \pm 0.04 in)

Adhesive applied width (B) : 8 ± 1 mm (0.31 \pm 0.04 in)

6. Using a helper, position the moonroof unit assembly frame over the body, visually aligning the paint marking marks. Then, lower the studs at each corner through the body panel holes, carefully installing the moonroof unit assembly to the body.
7. Press down lightly by hand only on the frame to expand the adhesive contact completely so that it resembles a compressed thickness (A), and a compressed width (B) between the moonroof unit assembly frame and the body.

Adhesive compressed thickness (A) : $5 +1.5/-0.5$ mm (0.20 +0.06/-0.02 in)

Adhesive compressed width (B) : 15 mm (0.59 in)

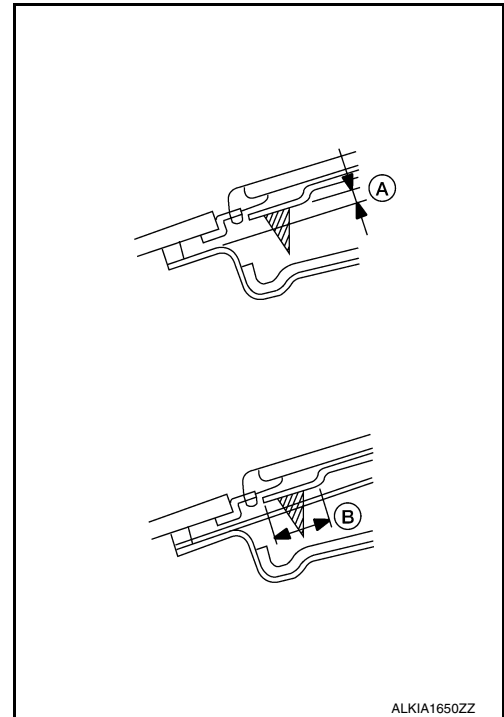

8. Install moonroof unit assembly nuts and bolts.
9. Install the sunshade carrier assembly. Refer to [RF-72, "Removal and Installation"](#).
10. Using a suitable tool, remove any adhesive overflow, or work into pocket voids so as to make the surface edge smooth.
11. Install the rear moonroof glass. Refer to [RF-67, "Removal and Installation"](#).
12. Install the rear window glass. Refer to [GW-27, "Removal and Installation"](#).
13. Install the roof finishers. Refer to [RF-63, "Removal and Installation"](#).
14. Install the front moonroof glass. Refer to [RF-64, "Removal and Installation"](#).
15. Connect the harness connectors to the moonroof motor assembly and sunshade motor assembly.
16. Install the wind deflector. Refer to [RF-70, "Removal and Installation"](#).
17. Install the glass lid. Refer to [RF-50, "Removal and Installation"](#).

NOTE:

MOONROOF UNIT ASSEMBLY

< REMOVAL AND INSTALLATION >

After installation, carry out fitting adjustment. Refer to [RF-27. "ADDITIONAL SERVICE WHEN REPLACING CONTROL UNIT : Special Repair Requirement"](#).

18. Install the antenna. Refer to [AV-196. "Removal and Installation"](#).
19. Install the headlining. Refer to [INT-48. "Removal and Installation"](#).
20. Check for water leaks.

NOTE:

- Perform the water leakage check more than 2 hours after moonroof unit assembly installation.
- After glass lid fitting adjustment, carry out water leakage check by spreading water over entire roof surface.

21. Remove the protective tape from the vehicle.

ROOF FINISHER

< REMOVAL AND INSTALLATION >

ROOF FINISHER

Removal and Installation

INFOID:000000012511777

For removal and installation of roof finisher. Refer to [RF-63. "Removal and Installation"](#).

A
B
C
D
E
F
G
H
I
J
RF
L
M
N
O
P

FRONT SUNROOF GLASS

< REMOVAL AND INSTALLATION >

FRONT SUNROOF GLASS

Exploded View

INFOID:000000012371177

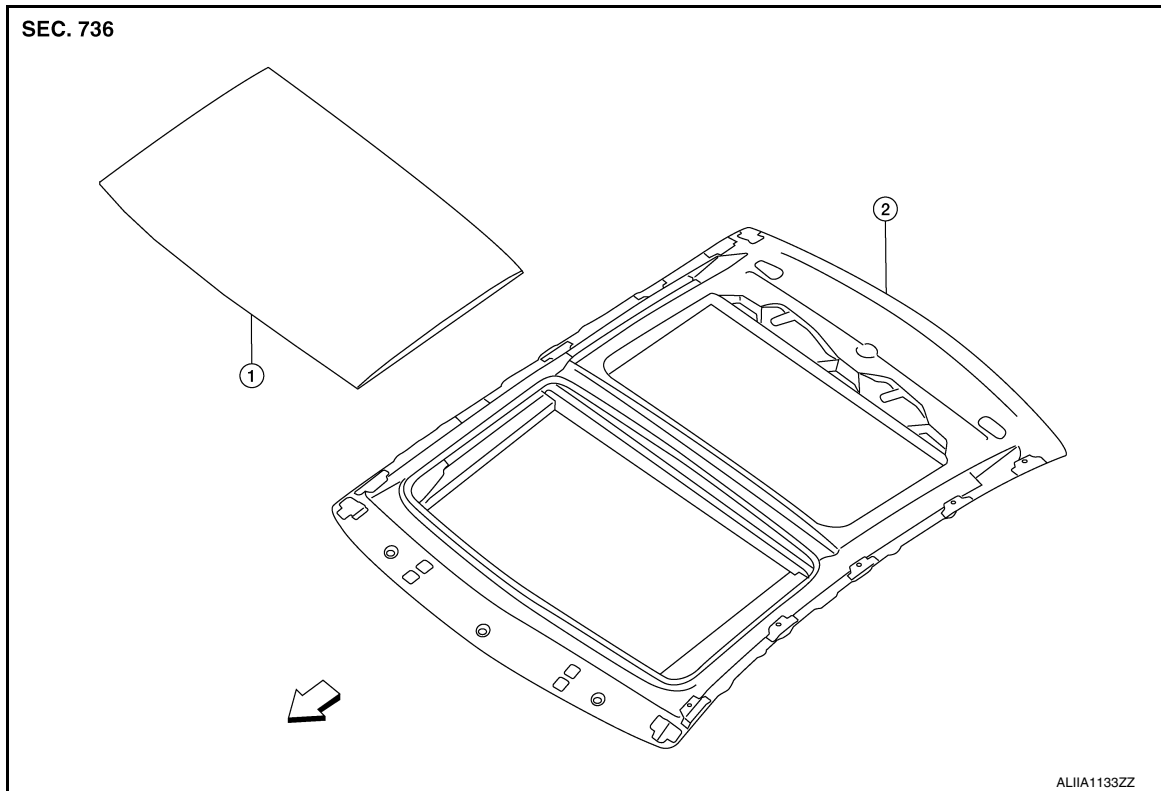

1. Front moonroof glass

2. Moonroof unit assembly

← Front

Removal and Installation

INFOID:000000012303630

REMOVAL

1. Remove the wind deflector. Refer to [RF-70, "Removal and Installation"](#).
2. Tape down the glass lid weatherstrip along the front moonroof glass with protective tape.
3. Apply protective tape around the front moonroof glass to protect the surface from damage.
4. Cut adhesive.
 - Pass piano wire through the adhesive with a wire pierce.
 - Tie piano wire on both ends to assist in wire grip.
 - Pull piano wire with a sawing motion to cut through the adhesive.
5. Remove the front moonroof glass.

INSTALLATION

WARNING:

- **Keep heat and open flames away as primers and adhesive are flammable.**
- **The materials contained in the kit are harmful if swallowed, and may irritate skin and eyes. Never let them contact the skin or eyes.**
- **Use in an open, well ventilated location. Never breathe the vapors. They may be harmful if inhaled. Move immediately to an area with fresh air if affected by vapor inhalation.**

NOTE:

- Use a genuine Nissan Urethane Adhesive Kit (if available) or an equivalent and follow the instructions furnished with it.
- Inform the customer that the vehicle should remain stationary until the urethane adhesive has completely cured (approximately 24 hours). Curing time varies with temperature and humidity.

FRONT SUNROOF GLASS

< REMOVAL AND INSTALLATION >

- Using a suitable tool, trim the adhesive (sealant) remaining on body down to approximately 2 mm thick (a) so that the contour becomes smooth.

CAUTION:

If bonded area on body is scratched, be sure to repair it with a 2-component urethane. Do not use lacquer.

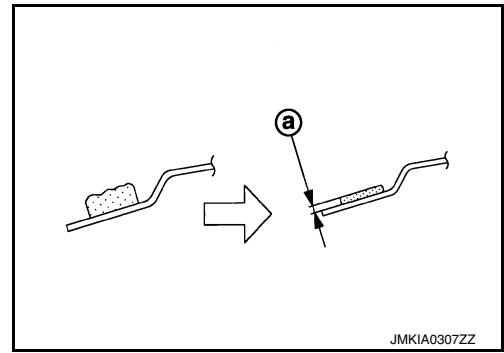

- When installing new front moonroof glass, position the front moonroof glass (no adhesive) first onto the vehicle and paint mating marks on the body and the front moonroof glass, then remove it again.
- Thoroughly clean bonding area on the front moonroof glass and the body with isopropyl alcohol or equivalent.
- Apply primer to the body and the front moonroof glass (lower) surfaces.
- Apply adhesive to the contact areas of the body within the time specified in the instructions for the adhesive.
 - Open adhesive by cutting off the nozzle tip and set it in a sealant gun.
 - Form a continuous bead of adhesive resembling the measurements in applied thickness (A), and in applied width (B) on the body panel.

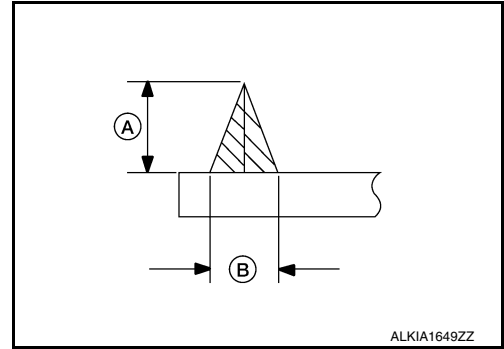

Adhesive applied thickness (A) : 13 ± 1 mm (0.51 ± 0.04 in)

Adhesive applied width (B) : 8 ± 1 mm (0.31 ± 0.04 in)

- Position the front moonroof glass, align the paint marks and lower it into position.
- Press down lightly by hand to evenly expand the adhesive contact with the front moonroof glass. Press down by hand to expand the adhesive contact completely so that it resembles a compressed thickness (A), and a compressed width (B).

Adhesive compressed thickness (A) : 5 +1.5/-0.5 mm (0.20 +0.06/-0.02 in)

Adhesive compressed width (B) : 15 mm (0.59 in)

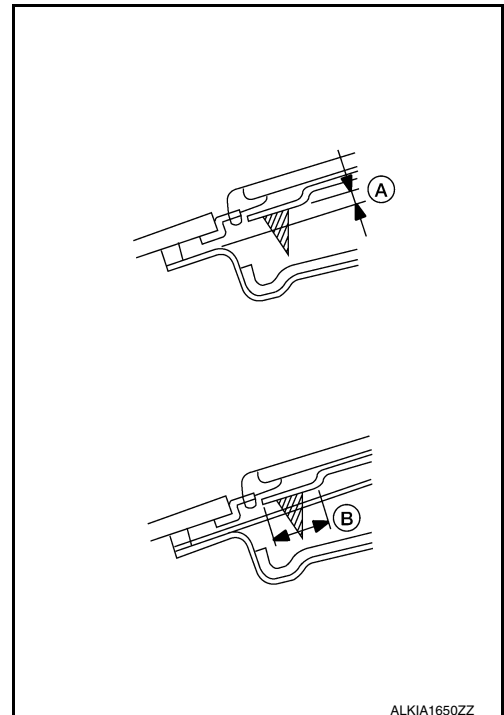

- Using a suitable tool, remove any adhesive overflow.

A
B
C
D
E
F
G
H
I
J
RF
L
M
N
O
P

FRONT SUNROOF GLASS

< REMOVAL AND INSTALLATION >

9. Remove the protective tape.

REAR SUNROOF GLASS

< REMOVAL AND INSTALLATION >

REAR SUNROOF GLASS

Exploded View

INFOID:0000000012371178

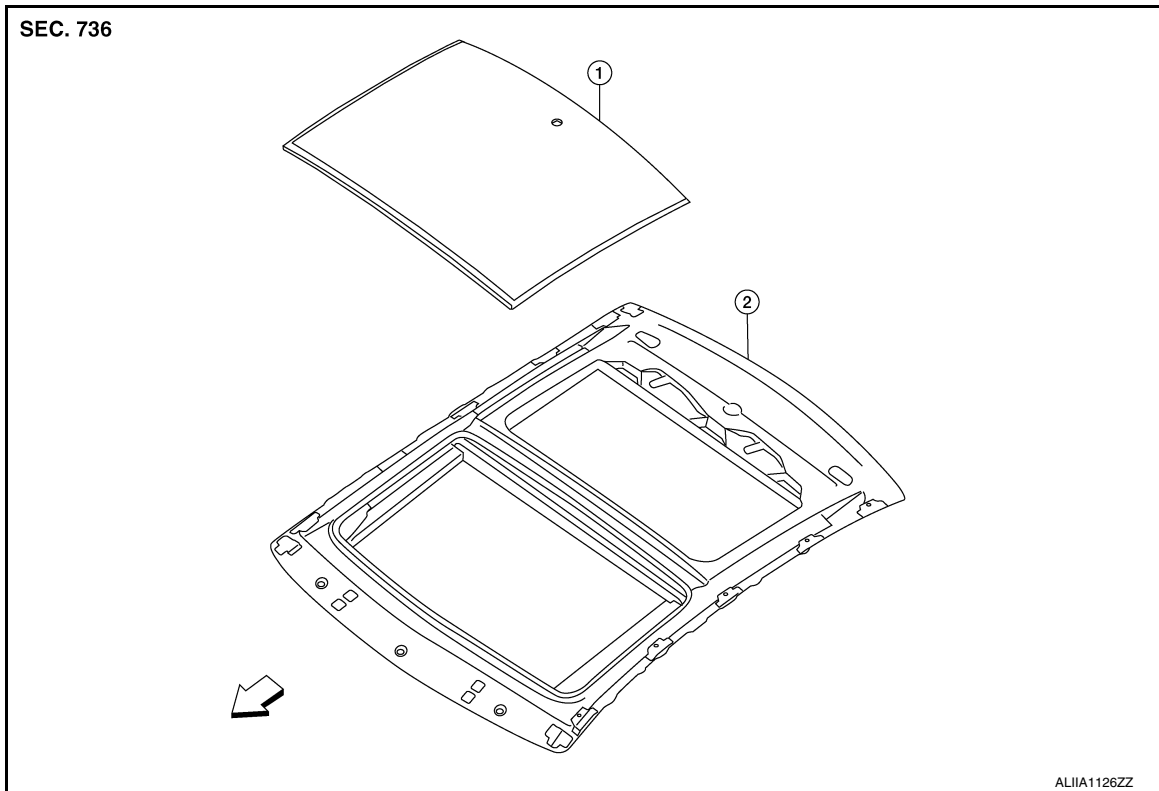

1. Rear moonroof glass

2. Moonroof unit assembly

← Front

Removal and Installation

INFOID:0000000012303631

REMOVAL

1. Apply protective tape around all of the glass panels to be removed.
2. Remove the satellite radio antenna. Refer to [AV-196, "Removal and Installation"](#).
3. Remove the rear window glass. Refer to [GW-27, "Removal and Installation"](#).
4. Remove the glass lid. Refer to [RF-50, "Removal and Installation"](#).
5. Remove the roof finishers (LH/RH). Refer to [EXT-38, "Removal and Installation"](#).
6. Cut adhesive.
 - Pass piano wire through the adhesive with a wire pierce.
 - Tie piano wire on both ends to assist in wire grip.
 - Pull piano wire with a sawing motion to cut through the adhesive.
7. Remove the rear moonroof glass.

INSTALLATION

WARNING:

- Keep heat and open flames away as primers and adhesive are flammable.
- The materials contained in the kit are harmful if swallowed, and may irritate skin and eyes. Never let them contact the skin or eyes.
- Use in an open, well ventilated location. Never breathe the vapors. They may be harmful if inhaled. Move immediately to an area with fresh air if affected by vapor inhalation.

NOTE:

- Use a genuine Nissan Urethane Adhesive Kit (if available) or an equivalent and follow the instructions furnished with it.

REAR SUNROOF GLASS

< REMOVAL AND INSTALLATION >

- Inform the customer that the vehicle should remain stationary until the urethane adhesive has completely cured (approximately 24 hours). Curing time varies with temperature and humidity.
1. Using a suitable tool, trim the adhesive (sealant) remaining on body down to approximately 2 mm thick (a) so that the contour becomes smooth.

CAUTION:

If bonded area on body is scratched, be sure to repair it with a 2-component urethane. Do not use lacquer.

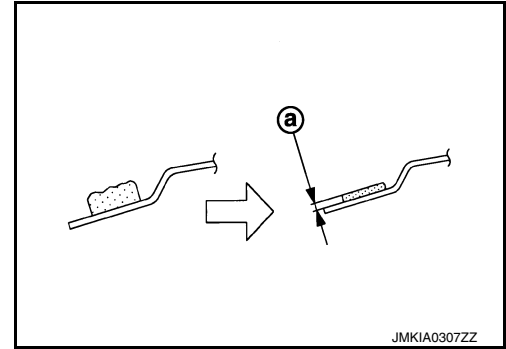

2. When installing new rear moonroof glass, position the rear moonroof glass (no adhesive) first onto the vehicle and paint mating marks on the body and the rear moonroof glass, then remove it again.
3. Thoroughly clean bonding area on the rear glass panel and the body with isopropyl alcohol or equivalent.
4. Apply primer to the moonroof frame anywhere the surface has been scratched and the rear moonroof glass (lower) surfaces.
5. Apply adhesive along the entire circumference of the rear moonroof glass frame contact area of the body within the time specified in the instructions for the adhesive. Also apply adhesive around the satellite antenna hole outward from the hole along the moonroof frame to cover the existing adhesive.
 - Open adhesive by cutting off the nozzle tip and set it in a sealant gun.
 - Form a continuous bead of adhesive resembling the measurements in applied thickness (A), and in applied width (B) on the sunroof frame.

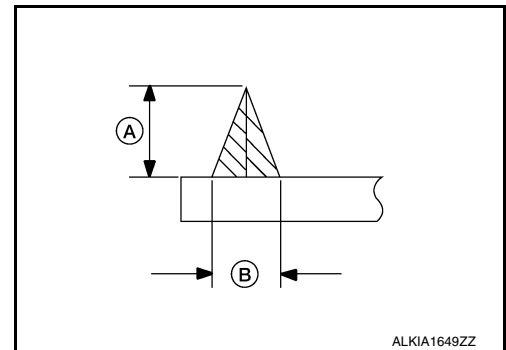

Adhesive applied thickness (A) : 13 ± 1 mm (0.51 ± 0.04 in)

Adhesive applied width (B) : 8 ± 1 mm (0.31 ± 0.04 in)

6. Position the rear moonroof glass, align the paint marks and lower it into position.

REAR SUNROOF GLASS

< REMOVAL AND INSTALLATION >

7. Press down lightly by hand to evenly expand the adhesive contact with the rear moonroof glass. Press down by hand to expand the adhesive contact completely so that it resembles a compressed thickness (A), and a compressed width (B).

Adhesive compressed thickness (A) : 5 +1.5/-0.5 mm (0.20 +0.06/-0.02 in)
Adhesive compressed width (B) 15 mm (0.59 in)

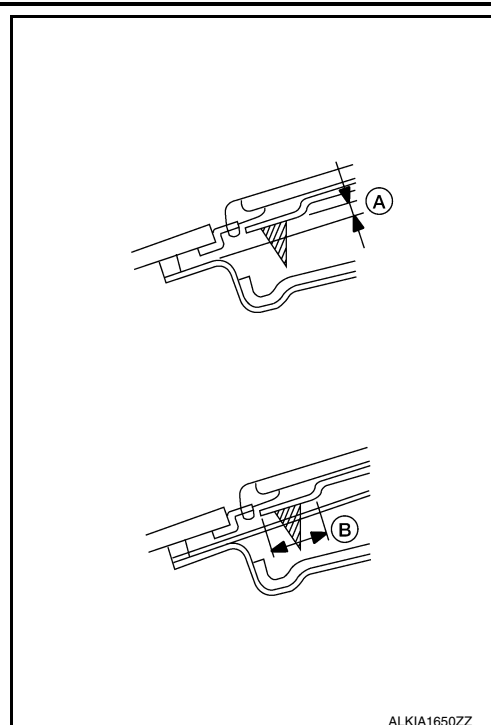

ALKIA1650ZZ

8. Install the rear window glass. Refer to [GW-27, "Removal and Installation"](#).
9. Install the roof finishers (LH/RH). Refer to [EXT-36, "Removal and Installation"](#).
10. Install the glass lid. Refer to [RF-50, "Removal and Installation"](#).
- NOTE:**
After installation, carry out fitting adjustment. Refer to [RF-57, "Inspection and Adjustment"](#).
11. Install the satellite radio antenna. Refer to [AV-196, "Removal and Installation"](#).
12. Check for water leaks.
- NOTE:**
- Perform the water leakage check more than 2 hours after moonroof unit assembly installation.
 - After glass lid fitting adjustment, carry out water leakage check by spreading water over entire roof surface.
13. Remove the protective tape from the vehicle.

WIND DEFLECTOR

< REMOVAL AND INSTALLATION >

WIND DEFLECTOR

Exploded View

INFOID:000000012371179

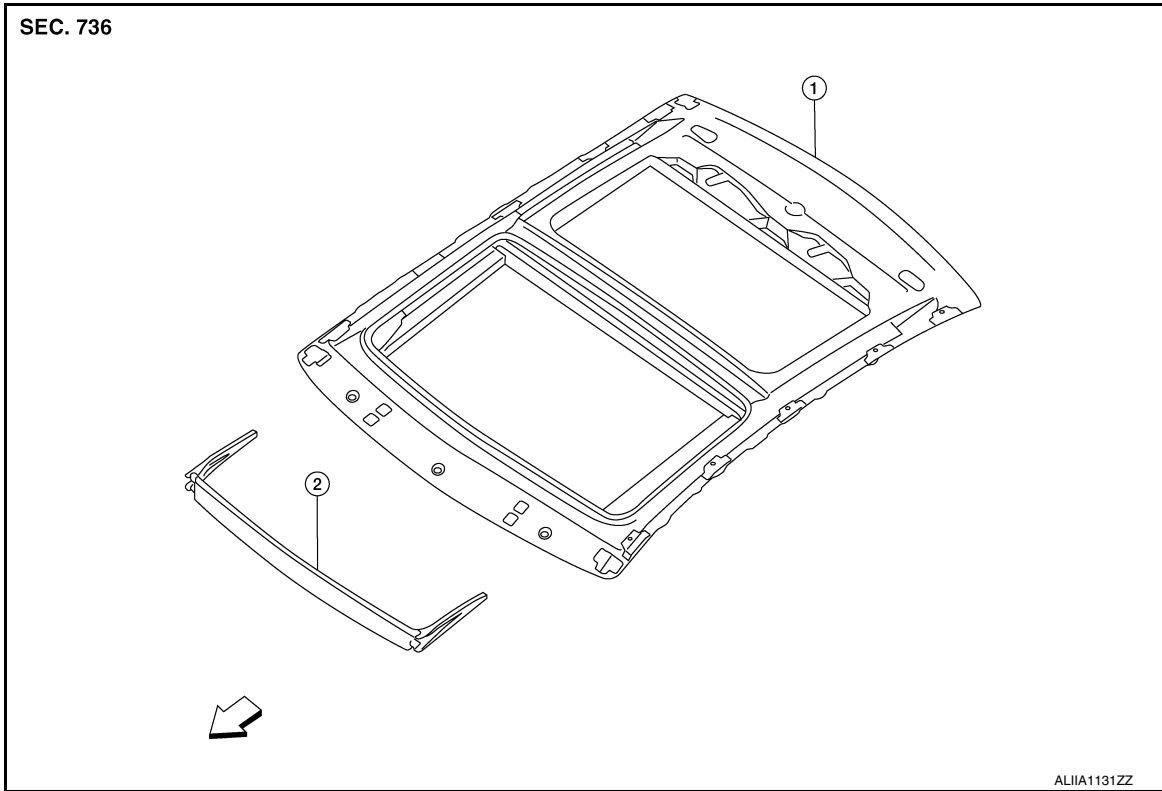

1. Moonroof unit assembly

2. Wind deflector

← Front

Removal and Installation

INFOID:000000012303632

REMOVAL

1. Open the glass lid.
2. Release pawls to slide back the wind deflector assembly (1).
3. Lift front of wind deflector to remove from slots.

 : Pawl

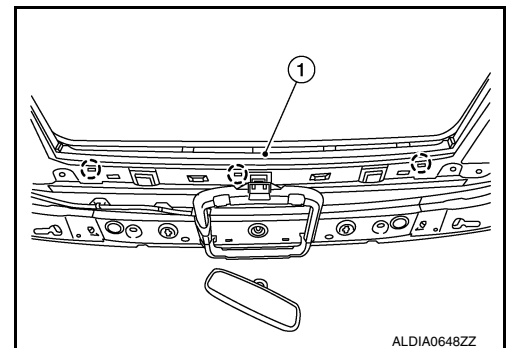

WIND DEFLECTOR

< REMOVAL AND INSTALLATION >

4. Release the pawls on each side arm, then slide forward to remove wind deflector from moonroof unit assembly.

⇐ : Front

○ : Pawl

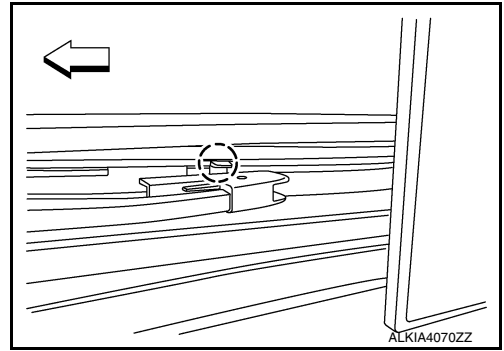

INSTALLATION

Installation is in the reverse order of removal.

A
B
C
D
E
F
G
H
I
J
RF
L
M
N
O
P

SUNSHADE

< REMOVAL AND INSTALLATION >

SUNSHADE

Exploded View

INFOID:000000012303633

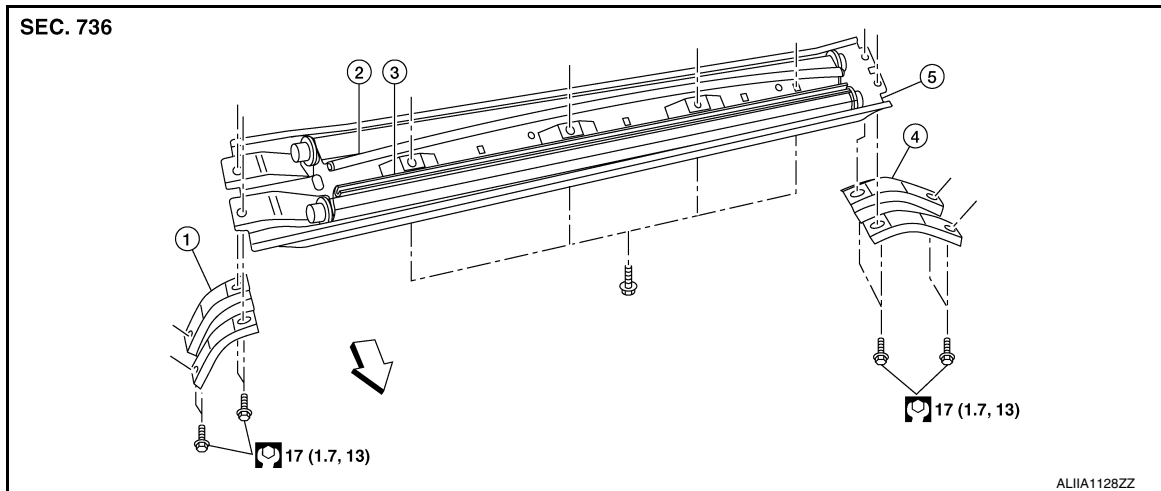

- | | | |
|------------------------|------------------------------|-------------------|
| 1. Center bracket (RH) | 2. Rear sunshade | 3. Front sunshade |
| 4. Center bracket (LH) | 5. Sunshade carrier assembly | ⇐ Front |

Removal and Installation

INFOID:000000012303634

REMOVAL

1. Open glass lid and sunshades.
2. Remove the headlining. Refer to [INT-48, "Removal and Installation"](#).
3. Release front sunshade rail (1) from sunshade drive post (2).

⇐ : Front

4. Release rear sunshade rail from sunshade drive post.
5. Remove side curtain air bag module bolts (two on each (LH/RH) sides) for access.
6. Release harness clips from sunshade carrier assembly.
7. Remove the center bracket bolts, then remove the center brackets (LH/RH).
8. Remove the sunshade carrier assembly bolts, then lower sunshade and remove from vehicle.
 - Release the end key slot from the sunshades.

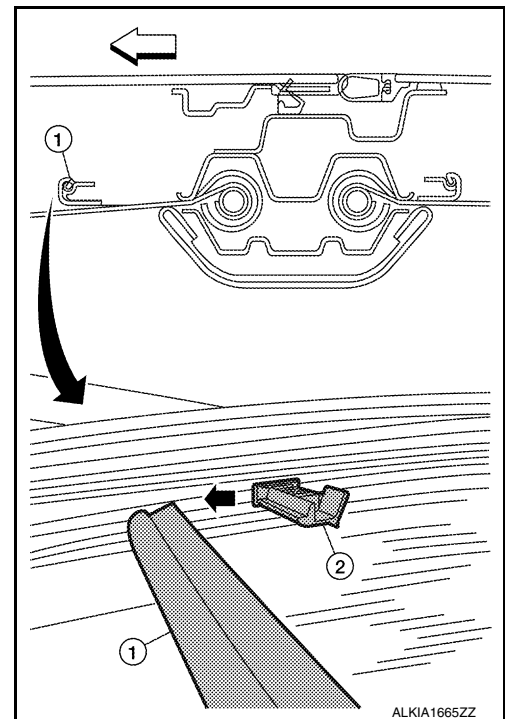

INSTALLATION

CAUTION:

Be careful not to release the spring when installing the sunshade.

1. Wind the shade around the core post.
2. Insert the round end of the shade (front - black curved rail) into the sunshade carrier assembly.

SUNSHADE

< REMOVAL AND INSTALLATION >

3. Using a suitable tool, wind the double-D tang end 20 turns counter-clockwise (when viewed from the end).
4. Insert the double-d tang end into the slot and lock it into the carrier.
5. Position the sunshade carrier assembly and install the bolts.
6. Position the center brackets (LH/RH) and install the bolts and nuts.
7. Install the side curtain air bag module bolts. Refer to [SR-22, "Explode View"](#).
8. Install the headliner. Refer to [INT-48, "Removal and Installation"](#).

A

B

C

D

E

F

G

H

I

J

RF

L

M

N

O

P

MOONROOF SWITCH

< REMOVAL AND INSTALLATION >

MOONROOF SWITCH

Removal and Installation

INFOID:000000012303635

The moonroof switch is serviced as an assembly with the front room/map lamp assembly. Refer to [INL-50](#), "[Removal and Installation](#)".